

# Motorized Screen Choices

Motorized Screen Models	Motor-in-Roller	Tensioning System	Automatic Ceiling Closure	Custom Case Finishes	Sizes Over 12' X 12'
<b>Ceiling Recessed</b>					
Access Dual Roller FlexShade	*				
Access MultiView/Series E	*				
Access MultiView/Series V	*	*			
Access/Series E	*				
Access/Series V	*	*			
Access Sonata/Series E	*				
Access Sonata/Series V	*	*			
Ambassador			*		
Envoy	*		*		
Paragon	*				*
Rolleramic					*
Signature/Series E	*		*		*
Signature/Series V	*	*	*		*
Ultimate Access/Series E	*		*		
Ultimate Access/Series V	*	*	*		
<b>Wall Mounted</b>					
Artisan/Series E	*			*	
Artisan/Series V	*	*		*	
Premier	*	*			
Silhouette/Series E	*				
Silhouette/Series V	*	*			
Targa	*				

# Motorized Screen Controls

## Single Station Control ①

Standard with most DRAPER electrically operated screens. Three-position rocker switch accepts 115V current. Switch operation is sustained contact. Complete with single-gang cover plate.



## 115 Volt Multiple Station Controls ①

Identical in appearance to SINGLE STATION CONTROL, see above. Automatic override allows only one signal to reach the motor when switches are operated simultaneously.

## \*Low Voltage Controls ② & ③

The most versatile control for your electric screens. Order the LOW VOLTAGE CONTROL unit without switches as an interface for a sophisticated master control system. Three-button switches and remote controls are also available, as shown. Switches have neutral decorator face plates for flush wall mounting. The LOW VOLTAGE CONTROL unit is also equipped with jacks for easy connection to DRAPER RF and IR receivers (see below). Wiring from control unit to switches or receivers is lightweight for 24 volt current. Optional for all DRAPER motorized screens, except ACCESS SONATA.



## \*Radio Frequency Remote Control ② & ④

Hand-held transmitter. 3-button control lets you raise or lower screen or adjust format at any point. Receiver plugs into the DRAPER LOW VOLTAGE CONTROL unit (required, see above).



## \*Infrared Remote Control ② & ⑤

Infrared transmitter and receiver. 3-button operation for instant access to "up", "down" and "stop" functions. Fully compatible with "learnable" IR master control systems. Receiver plugs into the DRAPER LOW VOLTAGE CONTROL unit (required, see above).



## Key Operated Power Supply Switch

Useful with any control system for a DRAPER electrically operated projection screen—low voltage or 115V. Switch mounts next to operating switch and controls power to it.



## Locking Switch Cover Plate

3-position control switch for limited access. Cover plate and locking switch cover are brushed stainless steel. Two keys furnished. 115V only.



## Key Operated 3-Position Switch

Similar to DRAPER's standard 3-position control switch, but requires a key for operation. 115V and low voltage style available. When used alone, a maintained contact switch is provided. With LOW VOLTAGE CONTROL ②, a momentary contact switch is provided and the low voltage control functions as a latching relay, so the screen will operate all the way up or down when the switch is activated. Two keys furnished.



## Individual/Group Control for more than one screen per room

The IGC-3N1 is a specialized low voltage control system designed for rooms with two or more motorized screens. Depending on the switches and remote transmitters that are ordered with the control, it is possible to operate screens in tandem, separately or both.



## \*Video Interface Control

Allows screen to be controlled by projector switch. When the projector comes on, the screen descends automatically. Model VIC115 integrates screen operation with equipment with a 115V switched outlet. Models VIC12 & VIC6 interface screen operation with equipment featuring a 12V switched outlet. The VIC115, VIC12 & VIC6 may be purchased with an override switch (VIC-OS), permitting independent operation. A VIC is not compatible with an LVC-III, built-in or otherwise.



*\*These optional controls may be factory-installed into the case of Access, Ultimate Access and Silhouette screens at no extra charge. Built-in controls may increase length of case, except for the Ultimate Access series. Call for exact dimension if critical. Choose either an LVC-III with or without a wireless transmitter, or choose a VIC. LVC-III and VIC are not compatible on a single motor, built-in or otherwise. Both may be used in an Access MultiView, which has two independently controlled motors.*

## Controls for Access Sonata

A programmable low voltage 6-button wall switch that DRAPER presets with four format settings is standard. Change to any format at the touch of one button! This switch is compatible with multiple stations and the optional SONATA IR remote control.



# Ultimate Access



*With an independently motorized ceiling closure.*

The ULTIMATE ACCESS offers all the advantages of the ACCESS, *plus an independently motorized ceiling closure.* In its closed position, the motorized closure forms a solid bottom panel giving the ceiling a clean appearance. At the touch of a switch or wireless transmitter, the door of the ULTIMATE ACCESS opens *into* the case before the viewing surface descends into the room. Your audience will be impressed by its precision timing and quiet, fluid movement.

No other projection screen offers you so many benefits. Refer to page 6 for the rewards of installing the ACCESS case during the “dirty” phase of the construction process. The screen (motor-in-roller with attached viewing surface) can be ordered, shipped and stored independently of the headbox, and popped into the case at a future date. Eliminates job site damage.

ULTIMATE ACCESS—the ultimate in projection screen design.

**Ultimate Access/Series V**—Features DRAPER’S TAB TENSIONING SYSTEM for a perfectly flat projection surface. Choose MI300, M2500, HiDEF GREY or CINEFLEX rear projection viewing surface. See page 14 for more on the benefits of TAB TENSIONING.

**Ultimate Access/Series E**—Your choice of a conventional viewing surface: fiberglass matt white, glass beaded, PANAMAX or acoustically transparent AT1200.

### System Options

- **Extra Drop**—Up to 12’ overall height, either white or black (white is standard for SERIES V in all formats and for SERIES E in AV format; black is standard for SERIES E in all other formats). Extra drop will increase the overall length of the case of a SERIES V.
- **Black Masking Borders**—Borders are optional for SERIES E in AV format. Borders are standard for SERIES E in all other formats and for all SERIES V screens.
- **Control Options**—Refer to page 5. Controls may be built into case and will increase the overall length of the case.
- **Screen/Case Options**—Left end motor location only.



CAPE Facility—IMMI, Westfield, IN.  
Dealer/Installer: Data Projections, Inc.

U.S. Patent No. 5,341,241 and 6,137,629. Other Patents Pending.

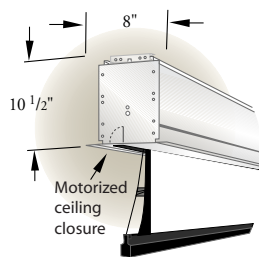

Ultimate Access/Series V

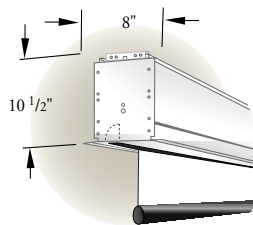

Ultimate Access/Series E

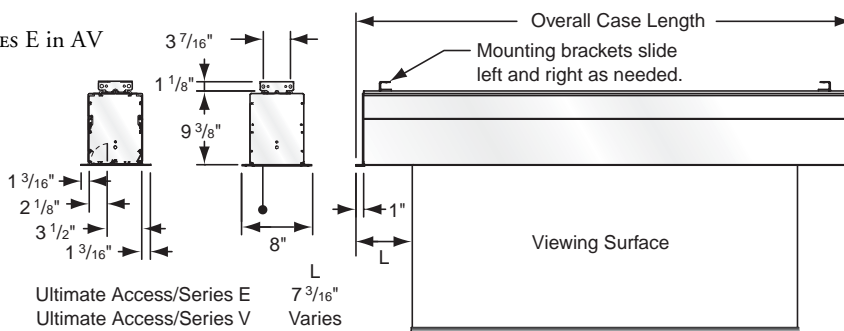

Ultimate Access/Series E 7 3/16"  
Ultimate Access/Series V Varies

Audio Visual Format	Series E			Series V		
	Case HxW	Net Wt. (lbs.)	Case Length*	Case Dowel Length	Net Wt. (lbs.)	Case Length*
50" x 50"	5'6 3/8"	82	6'3 7/8"	5'1 1/4"	84	6'3 7/8"
60" x 60"	6'4 3/8"	93	7'2 7/8"	6'1/4"	96	7'2 7/8"
70" x 70"	7'2 3/8"	98	8'7 7/8"	6'10 1/4"	100	8'7 7/8"
84" x 84"	8'4 3/8"	105	9'4 1/8"	8'1 1/2"	108	9'4 1/8"
6' x 8'	9'4 3/8"	129	10'2 7/8"	9'1/4"	134	10'2 7/8"
8' x 8'	9'4 3/8"	131	10'5 5/8"	9'3"	135	10'5 5/8"
7' x 9'	10'4 3/8"	134	11'4 1/8"	10'1 1/2"	138	11'4 1/8"
9' x 9'	10'4 3/8"	135	11'5 3/8"	10'3"	139	11'5 3/8"
8' x 10'	11'4 3/8"	141	12'5 3/8"	11'3"	144	12'5 3/8"
10' x 10'	11'4 3/8"	155	12'7 3/8"	11'4 3/4"	158	12'7 3/8"
9' x 12'	13'4 3/8"	157	14'5 3/8"	13'3"	160	14'5 3/8"
12' x 12'	13'4 3/8"	173	14'11 3/8"	13'8 3/4"	176	14'11 3/8"

\* In SERIES V, extra drop increases case length. Consult factory if this dimension is critical.

Complete Access Series specifications on page 60

NTSC Format (3:4)	Series E			Series V			
	Nominal Viewing Diagonal Area HxW	Case Length*	Net Wt. (lbs.)	Viewing Area HxW	Case Length*	Dowel Length	Net Wt. (lbs.)
6'	42 1/2" x 56 1/2"	6'4 3/8"	85	42 1/2" x 56 1/2"	6'10 3/8"	5'7 3/4"	87
7'	50" x 66 1/2"	7'2 3/8"	96	50" x 66 1/2"	7'8 3/8"	6'5 3/4"	99
100"	60" x 80"	8'4 3/8"	103	60" x 80"	8'10 7/8"	7'8 1/4"	106
10'	69" x 92"	9'4 3/8"	131	72" x 96"	10'2 7/8"	9'1/4"	134
11'	78" x 104"	10'4 3/8"	136	78" x 104"	11'1/8"	9'9 1/2"	140
150"	87" x 116"	11'4 3/8"	138	87" x 116"	12'1/8"	10'9 1/2"	142
15'	105" x 140"	13'4 3/8"	157	108" x 144"	14'5 3/8"	13'3"	160
<b>HDTV Format (9:16)</b>							
92"	45" x 80"	8'4 3/8"	100	45" x 80"	8'9 7/8"	7'7 1/4"	103
106"	52" x 92"	9'4 3/8"	127	52" x 92"	9'9 7/8"	8'7 1/4"	130
133"	65" x 116"	11'4 3/8"	134	65" x 116"	11'10 7/8"	10'8 1/4"	137
161"	79" x 140"	13'4 3/8"	152	79" x 140"	14'1/8"	12'9 1/2"	155
<b>WideScreen Format (1:1.85)</b>							
8'1/100"	47" x 87"	8'10 3/8"	105	47" x 87"	9'4 7/8"	8'2 1/4"	105
9'	50" x 92"	9'4 3/8"	127	50" x 92"	9'9 7/8"	8'7 1/4"	130
10'	56" x 104"	10'4 3/8"	130	56" x 104"	10'9 7/8"	9'7 1/4"	134
11'	63" x 116"	11'4 3/8"	134	63" x 116"	11'10 7/8"	10'8 1/4"	137
13'6"	76" x 140"	13'4 3/8"	152	76" x 140"	14'1/8"	12'9 1/2"	155

# Signature Series



*Automatic closure in sizes through 16' wide.*

The SIGNATURE SERIES offers the clean appearance of a ceiling-recessed screen in virtually any size, with any viewing surface. Ideal for boardrooms and meeting rooms. SIGNATURE's independently motorized aluminum ceiling closure disappears *into* the case when the screen is lowered, for a perfectly unobstructed view. Hinges are completely concealed, and the closure is supported for its entire length—no sag is possible. These exclusive features mean that the SIGNATURE SERIES is the best-concealed projection screen you've ever seen. Screen can be operated from any remote position.

**Signature/Series V**—Features DRAPER's TAB TENSIONING SYSTEM for a perfectly flat projection surface. Choose M1300, M2500, HiDEF GREY or CINEFLEX rear projection viewing surface. See page 14 for more on the benefits of TAB TENSIONING.

**Signature/Series E**—Your choice of a conventional viewing surface: fiberglass matt white, glass beaded, PANAMAX or acoustically transparent AT1200.

### System Options

- **Extra Drop, Series V**—Up to 14' overall height, either white or black (white is standard). \*Extra drop will increase case and dowel length. Consult DRAPER if this dimension is critical.
- **Extra Drop, Series E**—Up to 16' overall height, either white or black (white is standard for SERIES E in AV format; black for all other formats).
- **Black Masking Borders**—Borders are optional for SERIES E in AV format. Borders are standard for SERIES E in all other formats and for all SERIES V screens.
- **Control Options**—Refer to page 5. Controls may be built into case and will increase the overall length of the case.



*The Marten House—Hotel and Lilly Conference Center, Indianapolis, IN. Dealer: Electrical Systems Co.*

U.S. Patent No. 5,341,241

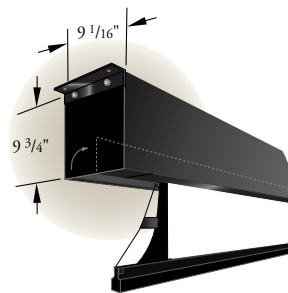

Signature Series V

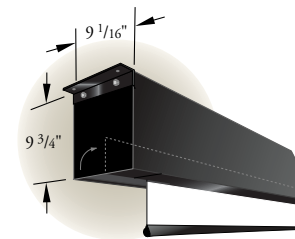

Signature Series E

Series E			Series V			Series E			Series V				
HxW	Case Length*	Net Wt. (lbs.)	Case Length*	Dowel Length	Net Wt. (lbs.)	Nominal Viewing Diagonal Area	Case HxW	Net Wt. (lbs.)	Viewing Area HxW	Case Length*	Dowel Length	Net Wt. (lbs.)	
<b>Audio Visual Format</b>						<b>NTSC Format (3:4)</b>							
50" x 50"	4'8 3/8"	52	5'6"	5'1 1/4"	63	6'	42 1/2" x 56 1/2"	5'6 3/8"	70	42 1/2" x 56 1/2"	6' 1/2"	5'7 3/4"	102
60" x 60"	5'6 3/8"	63	6'5"	6' 1/4"	75	7'	50" x 66 1/2"	6'4 3/8"	75	50" x 66 1/2"	6'10 1/2"	6'5 3/4"	106
70" x 70"	6'4 3/8"	75	7'3"	6'10 1/4"	84	100"	60" x 80"	7'6 3/8"	78	60" x 80"	8'1"	7'8 1/4"	125
84" x 84"	7'6 3/8"	84	8'6 1/4"	8'1 1/2"	98	10'	69" x 92"	8'6 3/8"	92	72" x 96"	9'5"	9' 1/4"	148
6' x 8'	8'6 3/8"	98	9'5"	9' 1/4"	109	11'	78" x 104"	9'6 3/8"	109	78" x 104"	10'2 1/4"	9'9 1/2"	159
8' x 8'	8'6 3/8"	109	9'7 3/4"	9'3"	110	150"	87" x 116"	10'6 3/8"	117	87" x 116"	11'2 1/4"	10'9 1/2"	180
7' x 9'	9'6 3/8"	110	10'6 1/4"	10'1 1/2"	124	15'	105" x 140"	12'6 3/8"	132	108" x 144"	13'9 1/2"	13'3"	210
9' x 9'	9'6 3/8"	124	10'9 1/2"	10'3"	125	200"	118" x 158"	14'5"	220	118" x 158"	15' 1/2"	14'6 3/4"	235
8' x 10'	10'6 3/8"	130	11'7 3/4"	11'3"	132	210"	126" x 168"	15'1"	225	126" x 168"	16' 1/2"	15'6 3/4"	240
10' x 10'	10'6 3/8"	132	11'9 1/2"	11'4 3/4"	136	220"	132" x 176"	15'9"	235	132" x 176"	16'8 1/2"	16'2 3/4"	250
9' x 12'	12'6 3/8"	153	13'9 1/2"	13'3"	156	230"	138" x 184"	16'5"	240	138" x 184"	17'6 1/2"	17' 3/4"	255
12' x 12'	12'6 3/8"	156	14'1 1/2"	13'8 3/4"	158	240"	141" x 188"	16'9"	245	144" x 192"	18'2 1/2"	17'8 3/4"	260
10'6" x 14'	14'9"	225	16' 1/2"	15'6 3/4"	240	<b>HDTV Format (9:16)</b>							
14" x 14'	14'9"	235	16'7 1/4"	16'1 1/2"	250	92"	45" x 80"	7'6 3/8"	78	45" x 80"	8'	7'7 1/4"	125
12' x 16'	16'9"	245	18'2 1/2"	17'8 3/4"	260	106"	52" x 92"	8'6 3/8"	92	52" x 92"	9'	8'7 1/4"	148
16' x 16'	16'9"	250	—	—	—	133"	65" x 116"	10'6 3/8"	109	65" x 116"	11'1"	10'8 1/4"	180
						161"	79" x 140"	12'6 3/8"	132	79" x 140"	13'2 1/4"	12'9 1/2"	208
						184"	90" x 160"	14'5"	210	90" x 160"	15' 3/4"	14'7"	225
						193"	94 1/2" x 168"	15'1"	215	94 1/2" x 168"	15'8 3/4"	15'3"	230
						220"	106" x 188"	16'9"	225	108" x 192"	17'10 1/2"	17'4 3/4"	240
						<b>WideScreen Format (1:1.85)</b>							
						8'100"	47" x 87"	8' 3/8"	90	47" x 87"	8'7"	8'2 1/4"	143
						9'	50" x 92"	8'6 3/8"	92	50" x 92"	9'	8'7 1/4"	148
						10'	56" x 104"	9'6 3/8"	105	56" x 104"	10'	9'7 1/4"	157
						11'	63" x 116"	10'6 3/8"	109	63" x 116"	11'1"	10'8 1/4"	180
						13'6"	76" x 140"	12'6 3/8"	132	76" x 140"	13'2 1/4"	12'9 1/2"	208
						182"	86 1/2" x 160"	14'5"	210	86 1/2" x 160"	15' 3/4"	14'7"	225
						190"	91" x 168"	15'1"	215	91" x 168"	15'8 3/4"	15'3"	230
						218"	102" x 188"	16'9"	225	104" x 192"	17'10 1/2"	17'4 3/4"	240

Case dimensions 9 3/4" high x 9 1/8" wide in sizes through 144" wide; 11" high x 9 1/8" wide in larger sizes.

Mounting brackets extend 1 1/2" beyond each end of case.



Complete Signature Series specifications on page 61



# Envoy

## Motor-in-roller screen with ceiling closure.

The ENVOY adds a touch of class to any presentation. The screen is recessed in the ceiling and invisible when not in use. At the touch of a switch an automatic ceiling closure opens and the screen appears. The ceiling closure can easily be finished to match the ceiling.

The ENVOY operates smoothly and silently. The motor is mounted inside the roller on special vibration insulators. The screen's slender profile makes it easy to install above most ceilings.

Your choice of a conventional viewing surface: fiberglass matt white, glass beaded or PANAMAX.

### System Options

- **Extra Drop**—Up to 12' overall height, either white or black (white is standard for AV format, black for other formats).
- **Black Masking Borders**—Borders are optional for AV format screens and standard for all other format screens.
- **Control Options**—Refer to page 5.

Complete Envoy specifications on page 61

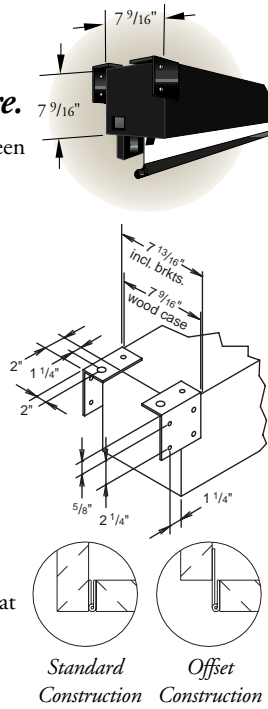

Carmel Clay Public Library Program Room, Carmel, IN.

Viewing Area HxW	Case Length	Net Wt. (lbs.)	Nominal Diagonal	Viewing Area HxW	Overall Size	Case Length	Net Wt. (lbs.)	Nominal Diagonal	Viewing Area HxW	Overall Size	Case Length	Net Wt. (lbs.)
<b>Audio Visual Format</b>			<b>NTSC Format (3:4)</b>			<b>HDTV Format (9:16)</b>			<b>WideScreen Format (1:1.85)</b>			
50" x 50"	5'5"	60	6'	42½" x 56½"	46½" x 59½"	6'3"	70	92"	45" x 80"	49" x 83½"	8'3"	80
60" x 60"	6'3"	70	7'	50" x 66½"	53½" x 69½"	7'1"	75	106"	52" x 92"	56" x 96"	9'3"	85
70" x 70"	7'1"	75	100"	60" x 80"	64" x 83½"	8'3"	80	133"	65" x 116"	69" x 120"	11'3"	115
84" x 84"	8'3"	80	10'	69" x 92"	73" x 96"	9'3"	85	161"	79" x 140"	84" x 144"	13'3"	120
6' x 8'	9'3"	85	11'	78" x 104"	83" x 108"	10'3"	105	<b>WideScreen Format (1:1.85)</b>				
8' x 8'	9'3"	100	150"	87" x 116"	92" x 120"	11'3"	115	8'100"	47" x 87"	51" x 90"	8'9"	82
7' x 9'	10'3"	105	15'	105" x 140"	109" x 144"	13'3"	120	9'	50" x 92"	54" x 96"	9'3"	85
9' x 9'	10'3"	115	Mounting brackets extend 2" in length beyond ends of case. Distance between hanger eyes is 2" greater than case length.									
8' x 10'	11'3"	115										
10' x 10'	11'3"	120										
9' x 12'	13'3"	120						11'	63" x 116"	67" x 120"	11'3"	115
12' x 12'	13'3"	130						13'6"	76" x 140"	80" x 144"	13'3"	120

# Ambassador

Complete Ambassador specifications on page 61

## Direct-drive motorized screen with ceiling closure.

The DRAPER AMBASSADOR is a direct-drive, heavy-duty, electrically operated screen designed specifically for recessed installation above any type of ceiling.

The AMBASSADOR features a fully automatic ceiling closure, which totally conceals the screen when not in use. The ceiling closure can be finished by the contractor to match the ceiling.

Your choice of a conventional viewing surface: fiberglass matt white or glass beaded.

### System Options

- **Extra Drop**—Up to 12' overall height, either white or black (white is standard).
- **Black Masking Borders**—optional.
- **Control Options**—Refer to page 5.

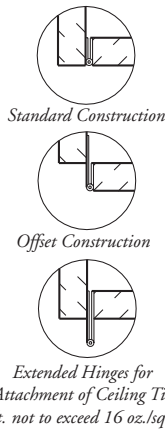
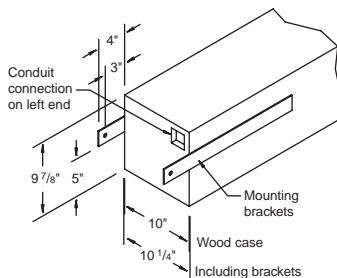

Viewing Area HxW	Case Length	Net Wt. (lbs.)
<b>Audio Visual Format</b>		
50" x 50"	6'2"	105
60" x 60"	7'	115
70" x 70"	7'10"	120
84" x 84"	9'	140
6' x 8'	10'	155
8' x 8'	10'	160
7' x 9'	11'	160
9' x 9'	11'	170
8' x 10'	12'	180
10' x 10'	12'	185
9' x 12'	14'	205
12' x 12'	14'	210

Mounting brackets extend 4" in length beyond ends of case.

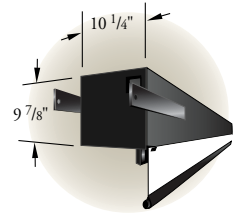

# Rolleramic

## Heavy-duty for big-screen presentations.

The ROLLERAMIC comes in sizes through 20' x 20' or 25' diagonal to accommodate your biggest presentations. All-wood case may be recessed in the ceiling or painted to match its surroundings. The viewing surface is concealed when not in use; lower it to any position at the touch of a switch. The direct drive module is mounted on rubber vibration insulators.

Your choice of a conventional viewing surface: fiberglass matt white, glass beaded or PANAMAX viewing surface.

### System Options

- **Extra Drop**—Up to 20' total screen height, either white or black.
- **Black Masking Borders**— Borders are optional for AV format screens and standard for all other format screens.
- **Triangular Shaped Steel Slat** at bottom of projection surface. With screen recessed above ceiling, the triangular slat can be set to stop flush with the ceiling, for a clean installation.
- **Mounting Brackets**—Universal brackets for wall or ceiling mount included, of 1/4" thick strap steel. Can also be installed above the ceiling line.
- **Control Options**—Refer to page 5.



Indiana University School of Law—Indianapolis

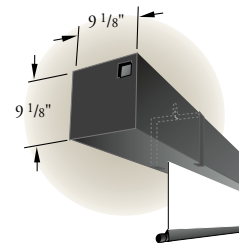

Viewing Area HxW	Case Length*	Net Wt. (lbs.)	Viewing Area HxW	Case Length*	Net Wt. (lbs.)	Viewing Area HxW	Case Length*	Net Wt. (lbs.)	Nominal Diagonal Area HxW	Overall Size	Case Length*	Net Wt. (lbs.)
<b>Audio Visual Format</b>									<b>NTSC Format (3:4)</b>			
50" x 50"	6'2"	90	9' x 9'	11' *	140	12' x 16'	18'6"	240	6'	42 1/2" x 56 1/2"	7'	95
60" x 60"	7'	95	8' x 10'	12' *	150	16' x 16'	18'6"	245	7'	50" x 66 1/2"	7'10"	105
70" x 70"	7'10"	105	10' x 10'	12' *	155	13'6" x 18'	20'6"	290	100"	60" x 80"	9'	120
84" x 84"	9'	120	9' x 12'	14' *	175	18' x 18'	20'6"	320	10'	69" x 92"	10'	130
6' x 8'	10'	130	12' x 12'	14' *	180	8' x 20'	22'6"	310	11'	78" x 104"	11' *	135
8' x 8'	10'	135	10'6" x 14'	16'6"	210	15' x 20'	22'6"	350	150"	87" x 116"	12' *	150
7' x 9'	11' *	135	14' x 14'	16'6"	220	20' x 20'	22'6"	380	15'	105" x 140"	14' *	175
									200"	118" x 158"	16'	210
									20'	141" x 188"	18'6"	240
									250"	148" x 198"	19'4"	285
									25'	177" x 236"	22'6"	350

Hangers extend 2 5/8" above case. \*Cases will be 6" longer with a PANAMAX viewing surface.

Complete Rolleramic specifications on page 61

# Paragon

## Motor-in-roller projection screen through 28' wide.

Choose the PARAGON for auditoriums, lecture halls and any setting where a very large screen is required. Sizes up to 21' x 28' for even the largest audiences. Case of aluminum and fire-retardant hardboard can be suspended anywhere, with controls wherever they're needed.

### System Options

- **Extra Drop**—Up to 21' total screen height, either white or black (white standard on AV format screens, black on all others).
- **Black Masking Borders**— Borders are optional for AV format screens and standard for all other format screens.
- **Control Options**—Refer to page 5.

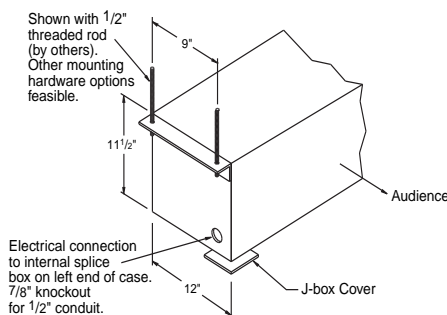

Complete Paragon specifications on page 61

Viewing Area HxW	Case Length	Net Wt. (lbs.)	Viewing Area HxW	Case Length	Net Wt. (lbs.)	Nominal Diagonal Area HxW	Overall Size	Case Length	Net Wt. (lbs.)
<b>Audio Visual Format</b>						<b>NTSC Format (3:4)</b>			
15' x 20'	20'10"	415	18' x 24'	24'10"	500	25'	177" x 236"	182" x 240"	415
20' x 20'	20'10"	430	13' x 26'	26'10"	515	27'6"	194" x 260"	199" x 264"	455
11' x 22'	22'10"	440	19'6" x 26'	26'10"	540	30'	212" x 284"	217" x 288"	500
16'6" x 22'	22'10"	455	14' x 28'	28'10"	555	32'6"	230" x 308"	235" x 312"	540
22' x 22'	22'10"	475	21' x 28'	28'10"	585	35'	248" x 332"	253" x 336"	585
12' x 24'	24'10"	475							

Mounting brackets extend 2" beyond each end of case.

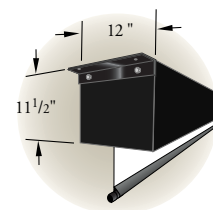



**Targa**



*Motor-in-roller design for smooth, quiet operation.*

TARGA—for beauty and reliability. DRAPER's motor-in-roller design allows viewing surface to be centered its one-piece steel case for a trim, balanced appearance. The motor is mounted inside the roller on special vibration insulators, so operating noise is dramatically reduced.

Your choice of a conventional viewing surface: fiberglass matt white, glass beaded or PANAMAX.

**System Options**

- **Case Color**—Dove grey (standard), black or white as shown.
- **Extra Drop**—Up to 12' overall height, either white or black (white is standard for AV format, black for other formats).
- **Black Masking Borders**—Borders are optional for AV format screens and standard for all other format screens.
- **Projected Mounting Brackets**—6" clearance for wall-mounted equipment below screen.
- **Control Options**—Refer to page 5.

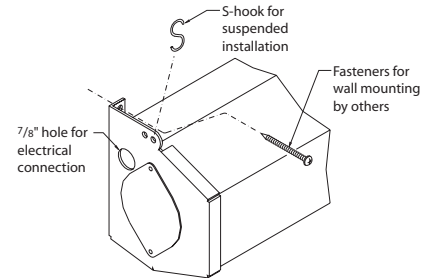
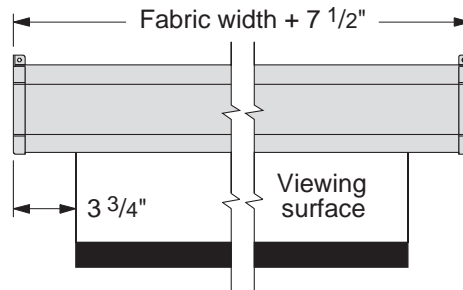
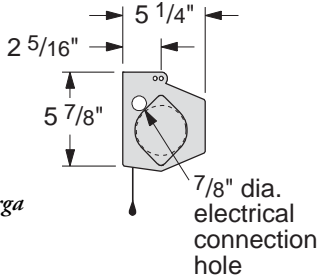
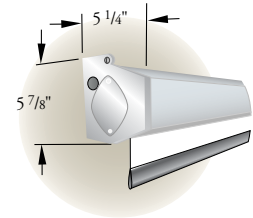

Complete Targa specifications on page 62

Viewing Surface HxW	Case Length	Net Wt. (lbs.)
<b>Audio Visual Format</b>		
50" x 50"	4'9"	24
60" x 60"	5'7"	28
70" x 70"	6'5"	33
84" x 84"	7'7"	37
6' x 8'	8'7"	41
8' x 8'	8'7"	42
7' x 9'	9'7"	44
9' x 9'	9'7"	46
8' x 10'	10'7"	50
10' x 10'	10'7"	54
9' x 12'	12'7"	57
12' x 12'	12'7"	62

Nominal Diagonal	Viewing Area HxW	Overall Size	Case Length	Net Wt. (lbs.)
<b>NTSC Format (3:4)</b>				
6'	42 1/2" x 56 1/2"	46 1/2" x 59 1/2"	5'7"	28
7'	50" x 66 1/2"	53 1/2" x 69 1/2"	6'5"	33
100"	60" x 80"	64" x 83 1/2"	7'7"	37
10'	69" x 92"	73" x 96"	8'7"	41
11'	78" x 104"	83" x 108"	9'7"	44
150"	87" x 116"	92" x 120"	10'7"	50
15'	105" x 140"	109" x 144"	12'7"	57

Case dimensions—5 3/16" high x 5 1/4" wide.  
Hanging brackets extend 5/8" above screen case.

Nominal Diagonal	Viewing Area HxW	Overall Size	Case Length	Net Wt. (lbs.)
<b>HDTV Format (9:16)</b>				
92"	45" x 80"	49" x 83 1/2"	7'7"	37
106"	52" x 92"	56" x 96"	8'7"	41
133"	65" x 116"	69" x 120"	10'7"	50
161"	79" x 140"	84" x 144"	12'7"	57
<b>WideScreen Format (1:1.85)</b>				
8'1/100"	47" x 87"	51" x 90"	8'1"	37
9'	50" x 92"	54" x 96"	8'7"	41
10'	56" x 104"	60" x 108"	9'7"	46
11'	63" x 116"	67" x 120"	10'7"	50
13'6"	76" x 140"	80" x 144"	12'7"	57

**Access Dual Roller FlexShade**

*When you need to install a projection screen in front of a window.*

DRAPER has a brand new approach to the problem of projection screens in front of window openings. With the new ACCESS DUAL ROLLER FLEXSHADE, you can have a motorized window shade that covers and seals the light from the opening, plus a projection screen with your choice of format and viewing surface, in the same recessed ACCESS headbox.

