

# **User Manual**

## **IP542N**

*V1.2*

## Revision Record:

<b>Version</b>	<b>Date</b>	<b>Author</b>	<b>Firmware Version</b>	<b>Applicability</b>
V1.0	2011-05-17	Anne	V1.2.5	
V1.1	2011-05-18	Anne	V1.2.5	
V1.2	2012-12-12	Maylin	V3.0	

# Table of Contents

<b>1 INTRODUCTION.....</b>	<b>7</b>
1.1 THANKS FOR PURCHASING IP542N.....	7
1.2 PACKAGE CONTENTS.....	7
<b>2 INSTALLING.....</b>	<b>8</b>
2.1 ASSEMBLING THE PHONE.....	8
2.2 MOUNTING THE PHONE TO THE WALL.....	8
2.3 TURNING ON THE PHONE.....	8
2.4 CONNECT TO THE INTERNET.....	9
2.4.1 Via Wired.....	9
2.4.2 Via Wireless.....	9
<b>3 GET FAMILIAR WITH IP542N.....</b>	<b>14</b>
3.1 FRONT PANEL.....	14
3.2 REAR PANEL.....	16
3.3 RIGHT PANEL.....	16
3.4 LEDS INDICATOR.....	17
3.5 GET FAMILIAR WITH LCD.....	17
3.5.1 Standby.....	17
3.5.2 LCD Menu.....	19
<b>4 MENU.....</b>	<b>20</b>
4.1 ITEMS.....	20
4.2 HOW TO CONFIGURATION FROM MENU.....	25
<b>5 USING BASIC PHONE FUNCTION.....</b>	<b>26</b>
5.1 USING THE HANDSET/ HANDSFREE/ HEADSET.....	26
5.1.1 Using the Handset.....	26
5.1.2 Using the Handsfree.....	26
5.1.3 Using the Headset.....	26
5.2 MAKING TELEPHONE CALL.....	26
5.2.1 Place a Call.....	26
5.2.2 Using Redial Button.....	26
5.2.3 Dialing from Phonebook.....	27
5.2.4 Dialing from Call History.....	27
5.2.5 Using Dial Plan.....	27
5.2.6 Using Delayed hotline.....	28
5.2.7 Answering a Telephone Call.....	28
5.3 ADJUSTING CALL VOLUME.....	28
5.4 BLACK LIST.....	29
5.5 MUTING A CALL.....	29
5.6 PLACING A CALL ON HOLD.....	29

5.7 THREE WAY CONFERENCE CALLS.....	30
5.8 ATTENDED TRANSFER.....	30
5.9 UNATTENDED TRANSFER.....	30
5.10 FORWARDING CALLS.....	31
5.11 CALL WAITING.....	31
5.12 ENDING A CALL.....	32
5.13 TEXT MESSAGE.....	32
5.13.1 Sending Message.....	32
5.13.2 Reading Message.....	33
5.14 DND (DO NOT DISTURB).....	33
<b>6 USING ADVANCED PHONE FUNCTIONS.....</b>	<b>34</b>
6.1 MSG.....	34
6.1.1 Enable and configuration MSG.....	34
6.1.2 Using MSG.....	35
6.2 CHANGING THE LCD SCREEN CONTRAST.....	35
6.3 CHANGING YOUR RING TONE.....	35
6.4 SETTING YOUR PHONE'S DATE AND TIME.....	35
6.5 REBOOTING YOUR PHONE.....	36
6.6 FACTORY DEFAULT.....	36
<b>7 CONFIGURATION.....</b>	<b>37</b>
7.1 WEB-BASED CONFIGURATION.....	38
7.2 WEBPAGE.....	39
7.3 STATUS.....	41
7.3.1 Basic.....	41
7.3.2 DHCP.....	42
7.3.3 Syslog.....	42
7.4 SIP ACCOUNT.....	43
7.4.1 SIP Settings.....	43
7.4.1.1 SIP Parameters.....	43
7.4.1.2 NAT Traversal.....	43
7.4.2 Line 1.....	43
7.4.2.1 Basic.....	44
7.4.2.2 Audio Configuration.....	44
7.4.2.3 Supplementary Services Subscription.....	45
7.4.2.4 Advanced.....	45
7.4.3 Line 2/3/4.....	46
7.5 NETWORK.....	46
7.5.1 Basic.....	47
7.5.1.1 Internet Port (WAN).....	47
7.5.1.2 PC Port (LAN).....	48
7.5.1.3 Network Address Server Settings (DHCP).....	49
7.5.2 Wireless.....	49

7.5.2.1	Wireless Settings.....	49
7.5.2.2	Wireless Connection.....	50
7.5.3	MAC Address Clone.....	51
7.5.4	VPN.....	51
7.5.5	DMZ.....	52
7.5.6	QoS.....	53
<b>7.6</b>	<b>PHONE.....</b>	<b>53</b>
7.6.1	Preference.....	53
7.6.1.1	Preference.....	53
7.6.1.2	Regional.....	54
7.6.1.3	Call Forward.....	54
7.6.1.4	Miscellaneous.....	55
7.6.2	Dial Plan.....	55
7.6.2.1	Parameters and Settings.....	55
7.6.2.2	Dial Plan Syntactic.....	57
7.6.2.3	Example.....	58
7.6.3	Phone Book.....	59
7.6.3.1	Black List.....	60
7.6.4	Call Log.....	62
7.6.4.1	Redial List.....	63
7.6.4.2	Answered Calls.....	63
7.6.4.3	Missed Call.....	64
<b>7.7</b>	<b>ADMINISTRATION.....</b>	<b>64</b>
7.7.1	Management.....	64
7.7.1.1	Time/Date.....	64
7.7.1.2	Password Reset.....	66
7.7.1.3	Web Access.....	67
7.7.1.4	System Log Setting.....	67
7.7.1.5	Factory Defaults.....	68
7.7.2	Firmware Upgrade.....	68
7.7.3	Security.....	69
7.7.4	Provision.....	70
7.7.5	SNMP.....	71
7.7.6	TR069.....	72
<b>8</b>	<b>TROUBLE SHOOTING.....</b>	<b>73</b>
8.1	NO OPERATION AFTER POWER ON.....	73
8.2	NO DIAL TONE.....	73
8.3	CAN NOT MAKE A CALL.....	73
8.4	CAN NOT RECEIVE ANY PHONE CALL.....	73
8.5	NO VOICE DURING AN ACTIVE CALL.....	73
8.6	CAN NOT CONNECT TO THE CONFIGURATION WEBSITE.....	74
8.7	FORGET THE PASSWORD.....	74

# 1 Introduction

## 1.1 Thanks for Purchasing IP542N

Thank you for purchasing IP542N. The IP542N which has 4 lines is a full-featured VoIP (Voice over Internet Protocol) phone that provides voice communication over an IP network.

This phone functions not only much like a traditional phone, allowing to place and receive calls and enjoy other features that traditional phone has, but also it own many data services which you could not expect from traditional telephone.

The IP542N provides **Power over Ethernet (PoE)** and two Ethernet ports for connecting another device to the local area network.

This guide will help you easily use the various features and services available on your phone.

The IP542N, which has a 3dB internal antenna for 802.11n 1T1R, supports wireless.

## 1.2 Package Contents

Your package includes the following:

- ◆ One IP542N (with PoE) IP Phone Unit
- ◆ Handset and handset cord
- ◆ One universal power adapter
- ◆ One Ethernet cable
- ◆ One base stand

## 2 Installing

### 2.1 Assembling the Phone

Step 1. Plug one end of the coiled phone cord into the left side of the phone base.

Step 2. Plug the other end of the handset cord into the jack at the bottom of the handset.

Step 3. If you are using an external power source, push the power cord into the power supply, and plug the power supply into the phone base unit.

**Note: Use only the power supply that came with the phone.**

### 2.2 Mounting the Phone to the Wall

Step 1. Complete the assembly instructions.

Step 2. Attach two appropriate screws to the wall. Leave 1/4 distance from the wall. This allows you to slide the mounting brackets on to the screws. Push down slightly to lock the phone in place.

### 2.3 Turning on the Phone

This section assumes that the correct connections have been made.

Step 1. Plug the AC power adapter into the electrical outlet.

**Note: Use only the adapter that came with the phone.**

Step 2. The LCD will firstly display “**Welcome, initializing.....**” and all of the lights on the phone will flash.

Step 3. Next, the LCD will display “**Initializing Network**”.

Step 4. After the sequence, the phone will display the Internet port IP address (if IP542N can connect to the Internet), date & time, lines status for the phone, and IP542N is started normally.

**Note: If the phone does not provide this screen, re-confirm installation and connections. If these are incorrect, try unplugging the phone and plugging it back in again. If you still don't see the display, then contact your Phone Administrator or service provider.**

## 2.4 Connect to the Internet

You can connect the IP542N to the Internet via wired and via wireless.

### 2.4.1 Via Wired

Step 1. Check IP542N have powered on correctly.

Step 2. Plug the Ethernet cable into **Internet port** in the rear side of the base station. Plug the other end of the Ethernet cable into your already prepared network connection.

Step 3. After the sequence, the IP Address of Internet port will appear at the bottom of the LCD.

### 2.4.2 Via Wireless

You can configuration wireless from LCD menu and from webpage.

#### From LCD menu:

Step 1. Press the **Menu** button, and then select **13Wireless** using the **UP and DOWN button**.

Step 2. Choose **2Wireless Connection** and you can view the wireless then IP542N can connect to.

Step 3. Highlight one network using the **UP and DOWN button**, and press the **softkey button under link** to connect.

Note: If the Wi-Fi need authentication, choose the authentication and fill in the password.

Step 4. Press the **softkey button under ok** to confirm connecting.

Step 5. If the AP has connected, the wireless icon in LCD will display linked.

#### From webpage:

Step 1. Login the web and then open **Network/Wireless** webpage.

[Status](#)
[SIP Account](#)
[Network](#)
[Phone](#)
[Administration](#)

[Basic](#)
[Wireless](#)
[MAC Address Clone](#)
[VPN](#)
[DMZ](#)
[QoS](#)

### Wireless Settings

**Wireless Settings**  
 Internet Connection Type: Automatic Configuration - DHCP  
 DNS Type: Auto  
 Primary DNS: 219.232.48.62  
 Second DNS: 219.141.140.10

### Wireless Connection

**Wireless Connection**  
 Connection Status: Connected (AP: E3CALL\_SZ[00:21:F2:01:37:31])

SSID	Authentication	Encryption	Status
E3CALL_SZ	WPA1PSK/WPA2PSK	TKIP/AES	
anyway	OPEN	NONE	
ChinaNet-zzXM	WPAPSK	TKIP	
T	home	TKIP/AES	

[Connect](#)
[Refresh](#)

Step 2.Highlight one Wi-Fi and the words will get larger, following is one example:

SSID	Authentication	Encryption
anyway	OPEN	NONE
E3CALL_SZ	WPA1PSK/WPA2PSK	TKIP/AES
T	home	TKIP/AES

[Connect](#)
[Refresh](#)

Step 3.Press the [Connect](#) button to connect to the E3CALL\_SZ.

Step 4.If the Wi-Fi need authentication, choose the authentication and fill in the password, then choose the [OK](#) button to connection

SSID	Authentication	Encryption
anyway	OPEN	NONE
E3CALL_SZ	WPA1PSK/WPA2PSK	TKIP/AES

T home TKIP/AES

Authentication WPAPSK

Encryption  TKIP  AES

Password

OK Cancel

Step 5.If the AP have connected, then connection status will change like following picture and the icon of wireless will display linked.

**Wireless Connection**

Connection Status: Connected (AP: E3CALL\_SZ[00:21:F2:01:37:31])

# 3 Get Familiar with IP542N

## 3.1 Front Panel

Front Panel	No.	Part Name	Description of function
	1	Handset top cradle	For the placement of handset (Receiver end)
		Hook switch	For hang-up and hang-off of handset
		Cradle latch	To prevent the handset from dropping when it is wall-mounted.
		Handset bottom cradle	For the placement of handset (Transmitter end)
		Handset cord port	RJ-11 jack on the left side of the IP phone
		Headset wire port	RJ-11 jack on the bottom of the handset
		Headset	To mount mouthpiece and earpiece on the single handle.
	2	LCD screen	The LCD screen is for displaying your settings, such as the IP address of you Internet port, phone number, and line status and so on.
	3	Line Keys	These keys are used as line keys; you can press the line button to select the corresponding line, and then user can make call or do other functions. The LEDs under the keys used to display the status of each extension, please refer to <b>3.4 LCD indicators</b> .

	4	Soft keys	These keys are used as soft keys. These can be used for item selection or control on the LCD screen. The softkey' function depends on their corresponding content displayed on the LCD at that time.
	5	MSG	<ul style="list-style-type: none"> <li>✧ The key can be used for voicemail selection, press it to access voicemail (must be set up by your phone administrator)</li> <li>✧ The LED is to indicate voicemail status. Please refer to <b>3.4 LCD indicator</b></li> </ul>
	6	Hold	The Hold key is used to hold the current call, press it again to release the hold function.
	7	Menu	Press it to access to menu items: such as phonebook, multi-functional key, and call history and so on.
	8	UP	To scroll up when configuration LCD menu
	9	VOL+	To turn up the volume
	10	OK	Press it to confirm
	11	Down	To scroll down when configuration LCD menu
	12	VOL-	To turn down the volume
	13	Handsfree	Press it to use Handsfree
	14	Headset	Press it to use headset.
	15	Mute/Del	<ul style="list-style-type: none"> <li>✧ During an active call, press it to mute the current call.</li> <li>✧ When input text, press it to delete a digit or number.</li> </ul>

	16	Numeric Keypad	Enters numeric digits for initiating a call or for entering configuration information.
--	----	----------------	--

### 3.2 Rear Panel

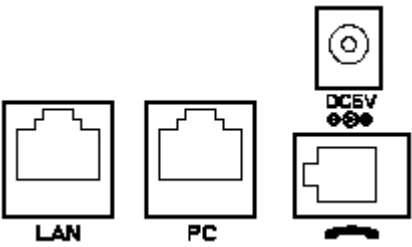
Rear Panel	Part Name	Description of function
	DC 5V	Power port
	PC	Connects to a PC
	LAN	Connects to the Ethernet switch, router or Internet.
	Headset	Headset console, connect to headset

### 3.3 Right Panel

Earphone

Following picture introduced the component of IP542N's earphone.

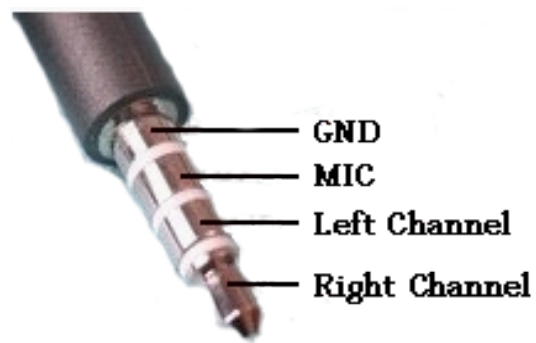



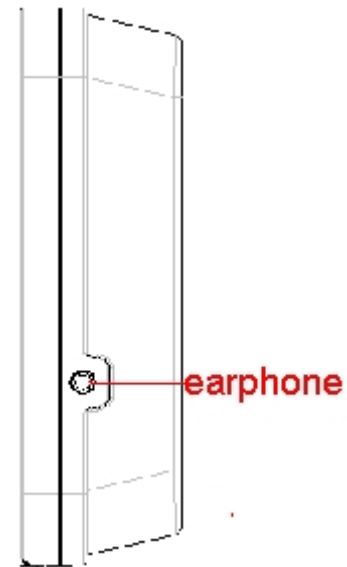

Earphone



Right Panel



## 3.4 LEDs Indicator

LED	Status	Description
	OFF	No new incoming call
	Blinking Red	NEW call incoming
 VoIP Lines 1/2/3/4	OFF	Line disable
	Solid Light Red	Not registered
	Solid Green	Registered, line is in standby
	Solid Red	Registered, line is in active call
	Blinking Red	New call incoming
 Mute	OFF	Off
	Solid Red	In mute
 Handsfree	OFF	Standby
	Solid Green	In use
 Headset	OFF	Standby
	Solid Green	In use

## 3.5 Get Familiar with LCD

### 3.5.1 Standby

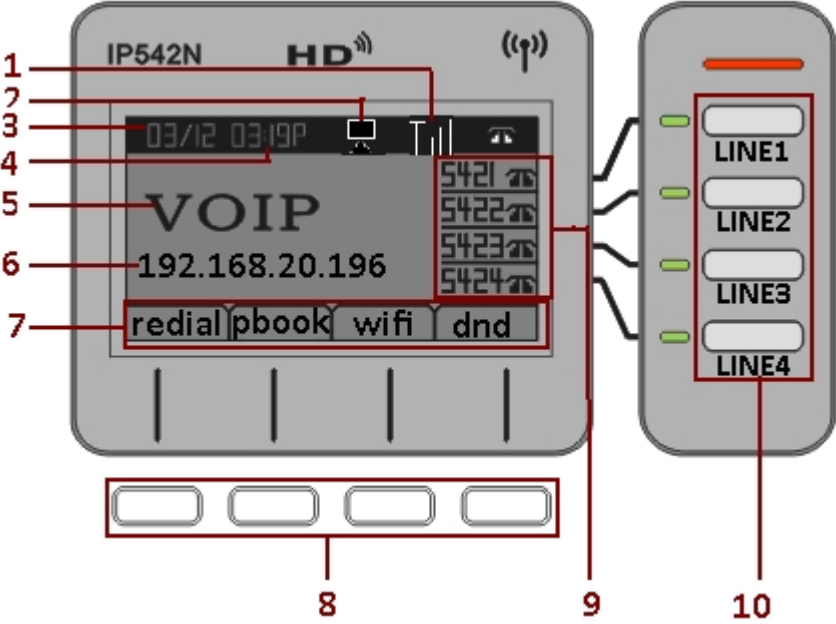
LCD	No.	Name	Description of function
	1	Date	To display the current date.

		Date format is mm/dd
	2	Time To display the current time. Time format is mm:ss (A or P)
	3	Wired Icon To display the status of wired connection
	4	Wi-Fi Icon To display the status of Wi-Fi connection
	5	Logo To display the name
	6	Internet port IP Address To display the current IP address of Internet ports if the Internet port have worked normally. Or to display the current IP address of WI-FI. If the port not connected, it will display 'WAN down'.
	7	Softkey Function To display the current softkey function.
	8	Softkey Button One softkey button mapping to one softkey function in LCD according to the wire between them.
	9	Phone Numbers Indicator To display the phone number of lines.
	10	Lines To display the status of lines. The icon  means unregistered. The icon  mean registered.

### 3.5.2 LCD Menu

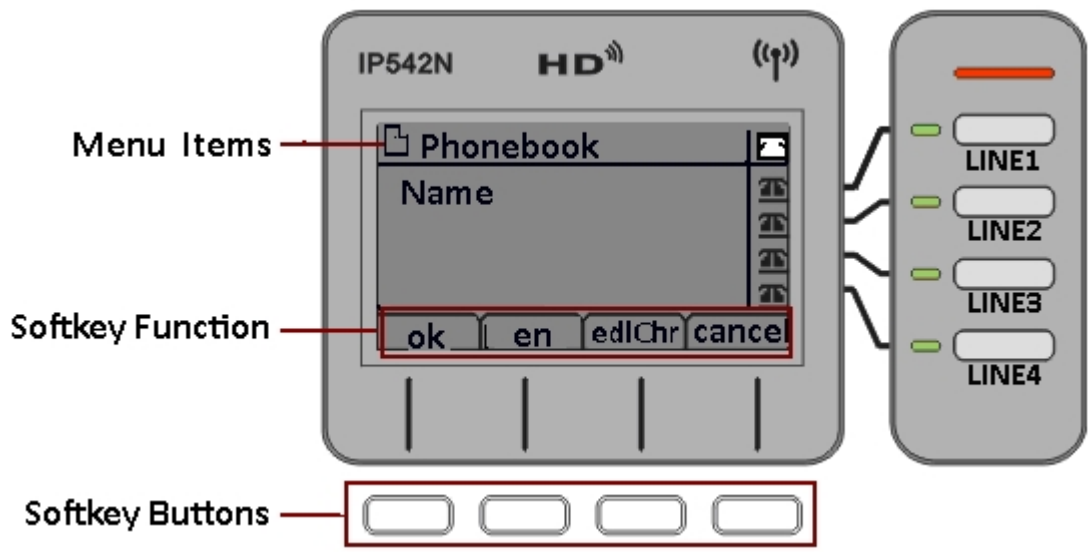
LCD	Name	Description of function
 <p>The diagram illustrates the LCD menu system. On the left, a mobile phone screen displays a 'Phonebook' menu item with a 'Name' field below it. At the bottom of the screen, four softkey functions are shown: 'ok', 'en', 'delChr', and 'cancel'. Below the screen, four physical softkey buttons are shown, each connected to a corresponding softkey function on the screen. On the right, a vertical strip of four buttons is labeled 'LINE1', 'LINE2', 'LINE3', and 'LINE4', each with a green indicator light above it.</p>	<b>Menu Items</b>	To display the items of menu.
	<b>Softkey Function</b>	To display the current softkey function.
	<b>Softkey Buttons</b>	<p>The softkey' function depends on their corresponding content displayed on the LCD at that time.</p> <p>Take the left picture for example:</p> <p>Press the first softkey button to choose ok</p> <p>Press the second softkey button to choose en</p> <p>Press the third softkey button to choose delChr</p> <p>Press the fourth softkey button to choose cancel</p>

## 4 Menu

User can use **MENU**, **soft keys**, and numeric keypad button to browse, modify and configuration the phonebook, multi-functional keys, network, accounts, factory default and so on.

### 4.1 Items

The table below lists Menu items which IP542N included:

<b>Main menu (LCD display)</b>	<b>Menu Items (LCD display)</b>	<b>Submenu Items (LCD display)</b>	<b>Explanation</b>
1Phonebook	1.1NewEntry		User can view, add, edit, and delete phonebook using the five softkey. User can also make call, and send text message directly using the five softkey. The Max records are 100.
3Call History	3.1RedialList		To list the latest 100 records of called call, answered call and missed calls.
	3.2Answered Calls		
	3.3Missed Calls		
4Text Message	4.1SEND		User can send message according to prompt.
	4.2Recived Box		To list the latest 100 records of received message and sent message.
	4.3SentBox		
5BlackList	5.1NewEntry		To configuration the blacklist, max record is 100.
6Preferences	6.1Call Waiting		To enable or disable call waiting
	6.2Auto Answer		To enable or disable auto answer.

7Ring Tone	7.1Bell Type1		Choose the ring tone from Bell Type1- Bell Type15.
	7.2Bell Type2		
	7.3Bell Type3		
	7.4Bell Type4		
	7.5Bell Type5		
	7.6Bell Type6		
	7.7Bell Type7		
	7.8Bell Type8		
	7.9Bell Type9		
	7.1Bell Type10		
8Volume Setting			To turn up or turn down volume.
9Accounts (need login password)	9.1Line 1	9.1.1Account Enable	To enable/disable line1.
		9.1.2Password	To set password of line1.
		9.1.3Account	To set account of line1.
		9.1.4Display Name	To set display name of line1.
		9.1.5Phone Number	To set the phone number of line1.
		9.1.6SIP Domain Name	To set the SIP domain name or domain name of line1.
		9.1.7SIP Server	To set the SIP server IP address of line1.
		9.1.8SIP Server Port	To set the SIP server port of line1.
		9.1.9Outbound Proxy	To set the outbound proxy IP address or domain name of line1.

		9.1.10Outbound Proxy Port	To set the outbound proxy port of line1.
	9.2Line 2	Same to 9.1	
10Call Forward	10.1CFWD AllNumber		To set the destination phone number of CFWD AllNumber
	10.2CFWD Busy Number		To set the destination phone number of CFWD Busy Number
	10.3CFWD No AnsNumber		To set the destination phone number of CFWD No AnsNumber
	10.4CFWD No AnsDelay		To set the destination phone number of CFWD No AnsDelay
11Time/Date	11.1Time(H:m:s)		
	11.2Date(m/d/y)		
12Voice Mail	12.1Line 1	12.1.1MWI Enable	To enable or disable voice mail of line1
		12.1.2Voice Mail Number	To set the voice mail number of line1.
	12.2Line 2	Same to 12.1	
13Network	13.1WAN Connection Type		To view the current Internet port's connection type, or to change the Internet port connection type from Static, DHCP and PPPoE.
	13.2CurrentIP		To view the current Internet port IP address, or to change the Internet port IP address.
	13.3CurrentNetmask		To view the Current Netmask, or to change the Current Netmask.

	13.4CurrentGateway		To view the Current Gateway, or to change the Current Gateway.
	13.5DNS1		To view the DNS1, or to change the DNS1.
	13.6DNS2		To view the DNS2, or to change the DNS2.
	13.7Enable WAN Login		To enable or disable user login webpage from Internet port.
	13.8Web Port		To view the Web Port, or to change the Web Port.
	13.9SIP QoS		To view the SIP QoS, or to change the SIP QoS.
	13.1RTP QoS		To view the RTP QoS, or to change the RTP QoS.
	13.11Data QoS		To view the Data QoS, or to change the Data QoS.
	13.12VLANID		To view the VLANID, or to change the VLANID.
	13.13802.1p Priority		To view the802.1p Priority, or to change the802.1p Priority.
13Wireless	13.1Wireless Settings	13.1.1WifiConnection Type	Choose the connection type from Static and DHCP
		13.1.2CurrentIP	To view the current Internet port IP address, or to change the Internet port IP address.
		13.1.3CurrentNetmask	To view the Current Netmask, or to change the Current Netmask.
		13.1.4CurrentGateway	To view the Current Gateway, or to change the Current Gateway.
		13.1.5DNS1	To view the DNS1, or to change the DNS1.
		13.1.6DNS2	To view the DNS2, or to change the DNS2.
13.2Wireless Connection	AP	To display the name of all APs.	
14Product INFO	14.1Product Name		To view the current information of Product Name, Software Version,

	14.2Software Version		Hardware Version and MAC Address.
	14.3Hardware Version		
	14.4MAC Address		
15Status	15.1Account1Status		To view the current information about the status of account1/2/3/4/5.
	15.2Account2Status		
	15.3Account3Status		
	15.4Account4Status		
	15.5Account5Status		
16Reboot			To reboot IP542N.
17Factory Default			To set IP542N factory default.
18Set Password			To reset password. The password of LCD is same as the one of Webpage. Default is null.
19LCD Contrast			To view and change the contrast of LCD.
20Login/Logout			Press it to logout LCD. IP542N will memory the password if user has input the password when access to <b>9Accounts</b> and IP542N will not request the password if user access to it again. Press <b>20Login/Logout</b> to erase memory, and then user should input password when user access to <b>9Accounts</b> again.

## 4.2 How to configuration from Menu

- 1) When the phone is on-hook, press the **MENU** button to enter Main menu.
- 2) Use the **Numeric Keypad** to input the digit or character
- 3) Press the **softkey button under en** to change the input method between digit, capital letter and small letter.
- 4) Use the **up** and **down softkey** to scroll up and down. Configuration the item or sub-item according to the prompt.
- 5) Press the **softkey button under ok** to confirm.
- 6) Press the **softkey button under save** to save changes.
- 7) Press **MUTE/DEL** button to delete one digit or a character.
- 8) Press the **softkey button under delChr** to delete one character
- 9) Press the **softkey button under cancel** to cancel changes and back to the up level.
- 10) The password access to item is the same as the one of admin mode when login Web, default is null.

# 5 Using Basic Phone Function

## 5.1 Using the Handset/ Handsfree/ Headset

### 5.1.1 Using the Handset

To place and answer calls using the handset, simply lift the handset.

### 5.1.2 Using the Handsfree

To place and answer calls using the Handsfree, press the **Handsfree** button. The green light behind the button will illuminate.

### 5.1.3 Using the Headset

To place and answer calls using the headset, press the **headset** button. The green light behind the button will illuminate.

## 5.2 Making Telephone Call

### 5.2.1 Place a Call

You can place a call by:

1. Lifting the handset and dialing phone number, followed by the # or wait 5 seconds, IP542N will dial out the phone number
2. Press the headset button and dial phone number, followed by the # or wait 5 seconds, IP542N will dial out the phone number
3. Press the Handsfree button and dial phone number, followed by the # or wait 5 seconds, IP542N will dial out the phone number

### 5.2.2 Using Redial Button

In standby, to redial the last number called:

Step 1.press the **softkey button under redial** to choose call history quickly

Step 2.use the softkey to choose **Redial List**

Step 3. highlight one phone number, and then press the **softkey button under dial** to redial the called number.

### 5.2.3 Dialing from Phonebook

#### Adding a phonebook

Below are the steps to add a phonebook in menu, and user can also add phonebooks from you PC using IP542N Web Interface

Step 1. Press **MENU** button to access to the menu items, and use the soft key button to choose **1.Phonebook**,

Step 2. Add one phonebook according to the prompt, press the **softkey button under en** to change the input method between digit, capital letter and small letter.

#### Using phonebook:

Press **MENU** button to access to the menu items, and use the soft key button to choose **1.Phonebook**, and then highlight the phonebook you want to call, press the **softkey button under dial** to make call immediately.

### 5.2.4 Dialing from Call History

Press **MENU** button access to the menu items, and use the **up** and **down buttons** to choose **3.CallHistory**, and then highlight the phone number you want to call, press the **softkey button under dial** to dial immediately.

### 5.2.5 Using Dial Plan

#### Adding one dial plan:

Step 1. Open **Phone/Dial Plan** webpage

Step 2. Add one dial plan, user can refer to **7.6.2 Dial Plan**

#### Using dial plan to make call:

Dial the phone number according to one dial plan.

## 5.2.6 Using Delayed hotline

Add the delayed hotline from **SIP Account/Account1/2/3/4** webpage, **User** column,

Step 1. Open **SIP Account/Account1/2/3/4/5** webpage, **User** column

Step 2. Fill in the delayed hotline number, user can also add the delayed time. below are two examples:

Example 1: Delayed Hot Line:  set the delayed hotline number is 111.

Example 2: Delayed Hot Line:  set the delayed hotline number is 111 and the delayed time is 4 seconds.

## 5.2.7 Answering a Telephone Call

When a call is incoming, the associated line button will flash and the phone will ring.

**You can receive the call by:**

Step 1. Pressing the corresponding line button or

Step 2. Pressing the Handsfree, or

Step 3. Lifting the handset, or

Step 4. Pressing the headset, or

Step 5. Auto-answer: if auto-answer is enabling, IP542N will answer the phone automatically when there is a call incoming

**Enable auto-answer:** press **MENU** button to access to the menu items, then use the **up** and **down button** to choose **6Reference**, set auto-answer enable according to the prompt.

**Note:** user can also enable auto-answer in **Phone/Preference** webpage, **miscellaneous** column.

## 5.3 Adjusting Call Volume

**From menu:**

Step 1. Press **Menu** button, and then choose **volume**.

Step 2. Press **VOL+** or **VOL-** **button** to turn up or turn down volume.

## 5.4 Black List

If user added a black list, IP542N will forbid the phone number incoming.

### Adding a black list:

There are two ways to add black list, one is from menu, and the other is from your PC to use IP542N's webpage.

### From menu:

Step 1. Press **Menu** button, and then choose **4black list**.

Step 2. Choose **NewEntry**, and then add one black list according to the prompt.

### From Webpage:

Step 1. Log on the web, open **Phone/Phonebook** webpage, **Black List** column.

Step 2. Refer to the **7.6.4.1 Black List** to add blacklist.

## 5.5 Muting a Call

During an active call, pressing the **MUTE** button to mute the handset, headset or Handsfree. This prevents the person on the active call from hearing what you or someone else in the room is saying; and the led behind the button change to red.

To cancel the Mute function, press the **MUTE** button again and the led return off.

## 5.6 Placing a Call on Hold

### When IP542N is during one active call:

Step 1. Pressing the **hold** button to put the active call on hold, then you will hear a dial tone, the remote party will hear the hold music

Step 2. User can input the phone number to make call

Step 3. Pressing the **hold** button again to release the previously Hold state and resume the bi-directional media.

## 5.7 Three Way Conference Calls

Step 1. To initiate a conference call, press the **HOLD** button during an active call and the first call is placed on hold, and you will hear a dial tone.

Step 2. Dial the second person's telephone number

Step 3. After the second person answers the call, press the **softkey button under CONF** button to start the conference call; all three parties will be participating in a conference call.

Step 4. If you hang up first, the other two parties will be disconnected; if one party hangs up first, you can go on talking with the other party.

## 5.8 Attended Transfer

You call the person to whom you are transferring the call and speak to them before transferring the call:

Step 1. To initiate a transfer; press the **HOLD** button during an active call. This places the first call on hold and you will hear a dial tone.

Step 2. Dial the second person's telephone number.

Step 3. When the second person answers, you can have a private conversation with the second person without the first person hearing it.

Step 4. To connect the call to the second person, press the **softkey button under XFER** button to complete the transfer. You will be disconnected from the call.

Step 5. If you hang up during the call with the second person before pressing the **softkey button under XFER**, the transfer is not completed; this only ends the call with the second person, and you can press the **HOLD** button to continue the first call.

## 5.9 Unattended Transfer

You can transfer an active call to a third party without announcement.

Step 1. To initiate an unattended (blind) transfer; press the **softkey button under XFER** button during an active call. The first call is placed on hold and you will hear a dial tone.

Step 2. Now dial the second person's telephone number with immediately ending char "#", IP542N will transfer phone automatically and you will

be disconnected from the call.

## 5.10 Forwarding Calls

You can forward all calls, forward calls when the phone is busy or forward calls when there is no answer.

Below are the steps to configuration call forward from menu. You can also set call forwarding options from your PC using the IP Phone Web Interface.

### **From menu:**

Step 1. Press the **MENU** button.

Step 2. Select **9Call Forward** and choose one type of call forwarding.

- CFWD All Number—Forwards all calls to a single number immediately when there is an incoming call.
- CFWD Busy Number—Forwards all calls to another number when the phone is busy.
- CFWD No Ans Number—Forwards calls to another number if there's no answer at your phone.
- CFWD No Ans Delay—the seconds to delay forwarding calls, if there is no answer at your phone.

Step 3. Fill in the call forwarding number.

Step 4. Press the **softkey button under ok** to confirm changes and then press the **softkey button under save** to save changes.

## 5.11 Call Waiting

Before using call waiting, you should enable it firstly, and default is enabling.

### **During an active call:**

Step 1. If call waiting is enabled, call waiting alerts you with ringing if there is another call is incoming, and the associate line button will change to red blinking, press the line key of the second call to answer the second call with the first call holding, pressing the line button of the first call to back to the first call with the second call holding.

Step 2. If the call waiting is off, new calls would be rejecting and the new caller will hear busy tone when you are on another call.

### **Enable Call Waiting:**

You can turn call waiting on or off from menu in **Menu/6References** item.

User can also enable call waiting by using your PC to open **SIP Account/Account X (1/2/3/4)** webpage, **User** column.

## **5.12 Ending a Call**

To end a handset call, hang up the handset.

To end a Handsfree call, press the Handsfree button.

To end a headset call, press the headset button.

## **5.13 Text Message**

### **5.13.1 Sending Message**

Step 1.Press **Menu** button, and then choose **3Text Message** by using the **up button** or the **down button**.

Step 2.Press the **softkey button under select** to enter to **1SEND** item.

Step 3.Press the **softkey button under select** to edit message.

**Note:** When inputting text, use the **softkey button under en** to change the input method among numbers, capital and lowercase English letters, **en** stands lower case, **EN** stands capital letter, and **num** stands digit

Step 4.Press the **softkey button under ok** to input **receivers' phone number**.

**Note:** IP542N support group mails, user can send one message to 10 friends or family one a time;

Press the **softkey button under ok** to access to input the next receiver's phone number;

You can also select one number in phonebook by pressing the **softkey button under pbook**.

If user has configuration the phone numbers which you want to send, press the **softkey button under ok** twice to access to the next item (**Sender number**).

Step 5.Set Sender phone number, default is line1's phone number.

Step 6. Press the **softkey button under select** to send message.

### 5.13.2 Reading Message

Step 1. Press **Menu** button, and then choose **3Text Message** by using the **up button** or the **down button**.

Step 2. Press the **softkey button under select** to enter to **2Recived Box** item or **Sent Box** item.

Note: In Received Box are messages have received from others including new messages and old messages. The ones in Sent Box are messages have sent out.

Step 3. Press the **softkey button under select** to access to the next item. Choose the message you want to read by using the **up button** or the **down button**.

## 5.14 DND (Do Not Disturb)

Use the Do Not Disturb feature to prevent incoming calls when sometimes you don't want somebody interrupt.

To enable Do Not Disturb, just press the **softkey button under dnd**, then the LCD will display "Do Not Disturb" under the IP address of Internet port and the function name of the softkey will change to **-dnd**.

Press the **softkey button under -dnd** again to disable Do Not Disturb.

# 6 Using Advanced Phone Functions

## 6.1 MSG

Voice Mail service must be available on your network to use this feature.

### 6.1.1 Enable and configuration MSG

There are two ways to enable MSG, one is from menu, and the other is from your PC to use IP542N's webpage.

#### From Menu:

Step 1. Press **Menu** button to enter menu items and then choose **11Voice Mail**

Step 2. Highlight the line you want to configuration, and then select it

Step 3. And then use the **softkey buttons** to configuration it according to the prompt

Step 4. Press the **softkey button under save** to save the changes

#### From Webpage:

Step 1. Log into Web, open **Account X (1/2/3/4) /User webpage**.

Step 2. Enable **MWI Enable** and fill in the **Voice Mailbox Numbers** (get the number from your phone administrator), below is a settings example based on Asterisk.

User			
<b>Supplementary Services</b>			
Call Waiting:	Enable		
Dial Prefix:		Delayed Hot Line:	
MWI Enable:	Enable	Voice Mailbox Numbers:	*97

Step 3. Press  button to save changes, then the notice **Please REBOOT to make the changes effective!** will appear, press  button to make changes effective.

## 6.1.2 Using MSG

To access you voice mail box, press the **MSG** button.

Then user can listen to the new voice mail or old voice mail or reply voice mail according to the voice prompt.

## 6.2 Changing the LCD Screen Contrast

Step 1.Press the **Menu** button, scroll to **19LCD Contrast**, and press the **softkey button under Select** to access.

Step 2.Use the **up** and **down buttons** to adjust the screen contrast. Press the **Up** button to increase the contrast. Press the **Down** button to decrease the contrast.

Step 3.Press the **softkey button under save** to save changes.

## 6.3 Changing Your Ring Tone

**To change a ring tone:**

Step 1.Press the **Menu** button and then select **6Ring Tone**.

Step 2.Use the **up** and **down** buttons to highlight one ring tone.

Step 3.Press the **softkey button under select** to set the highlighted ringtone.

## 6.4 Setting Your Phone's Date and Time

The date and time for your phone normally come from the phone server. However, if you need to change some date and time parameters, you can follow these steps:

Step 1.Press the **Menu** button, select **10Time/Date**.

Step 2.Choose date to adjust date; enter the date in the format: mm/dd/yy.

Step 3.Choose time to adjust time; enter the time in the format: hh/mm/ss.

Step 4.Press the **softkey button under ok** to save the changes.

## 6.5 Rebooting Your Phone

This setting is to configure and troubleshoot the network. You should not change these settings unless directed to by your Administrator as this can negatively affect your phone's function.

### To reboot your phone:

Step 1. Press the **Menu** button, Scroll to 16Reboot

Step 2. Press the **softkey button under select** to access to reboot item.

Step 3. Then a notice "Confirm System Reboot" will appear, press the **softkey button under ok** to confirm rebooting.

## 6.6 Factory default

There two ways to make factory default: from menu and from your PC to use IP542N's webpage.

### From menu:

Step 1. Press **Menu** button and choose 17**factory Default**

Step 2. Press the **softkey button under select** to access to factory default item.

Step 3. Then a notice will appear, press the **softkey button under ok** to continue.

### Using Website:

Step 1. Access to website, open **Administration/Management** webpage;

Step 2. Press the **factory default** button at the bottom of the webpage;

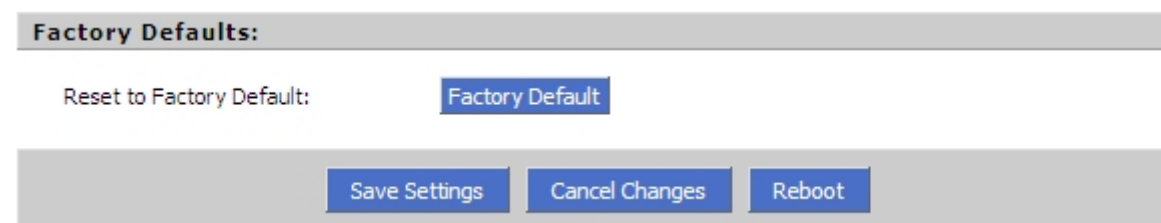

Step 3. Waiting about 5 seconds, the red notice *Please REBOOT to make the changes effective!* will appear, and then press **Reboot** button to reboot IP542N.

Note: If you choose factory default, you will return the phone to the original factory settings and will erase all current settings, including the directory and call logs.

# 7 Configuration

## 7.1 Web-based Configuration

This section will show you how to configure your IP542N using the web-based configuration interface. The default network settings are the following:

Default Internet Connection Type: **DHCP**

Default PC Port Connection Type: **Bridge**

Default user name of admin mode: **admin**

Default user name of user mode: **user**

Default password of Web: **(null)**

Default Web login port: **8080**

Web Idle Timeout: **5 min**

To access the phone through a web browser,

Step 1. Setup IP542N correctly

Step 2. Lookup the Internet IP Address in the left side of LCD

Step 3. Enter “**http://Internet IP Address:8080**” in the address field of the browser.



Step 4. Type “**admin**” or “**user**” for the User Name, click on the **Login** button to access the configuration page

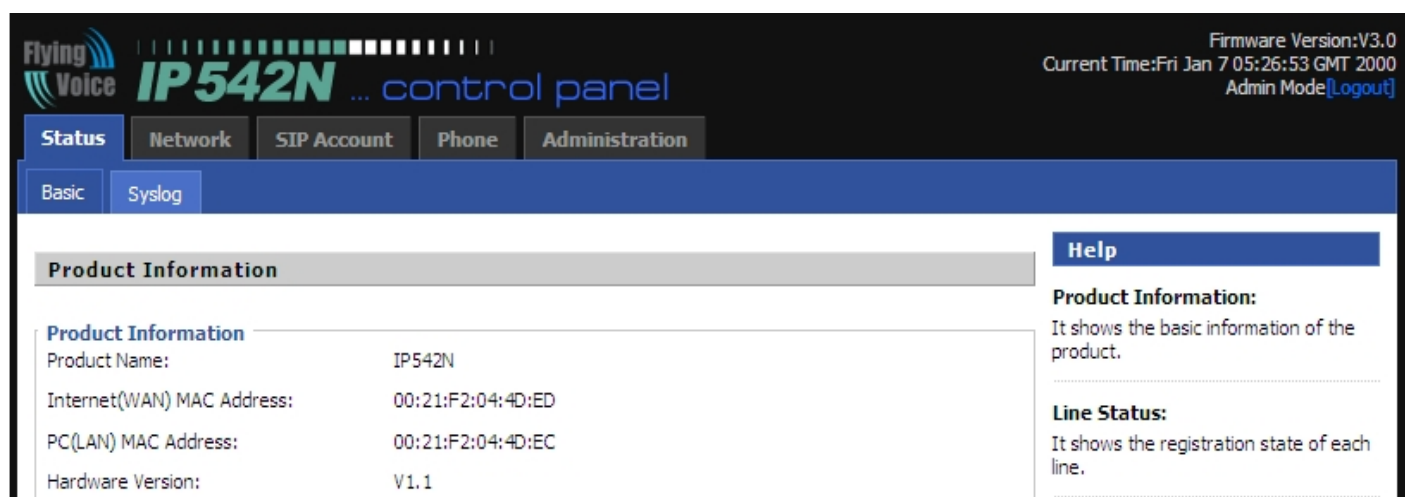

There are two levels of web configuration: one “user” ID level that can view just some portion in the web, and the other “admin” ID level that can view and configure all settings in the web-based configuration interface. To use “admin” ID for login, please contact

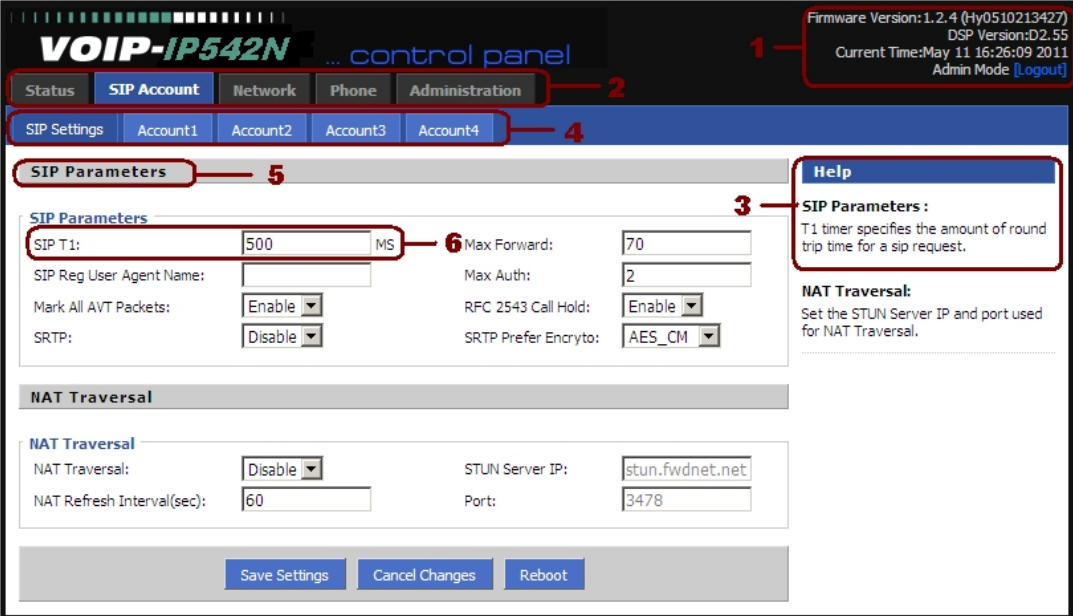
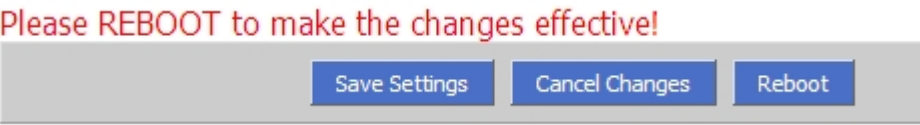

your administrator, supplier or service provider.

## 7.2 Webpage

	No.	Name	Description
	1	main information	Display the firmware version, DSP version, Current Time, and administration mode. Press <b>Logout</b> button to logout.
	2	navigation bar	Click navigation bar, many sub-navigation bar will appear in the place 4.
	3	Help	Display the main information for configuration; user can get help from it directly.
	4	sub-navigation bar	Click sub-navigation bar to enter to configuration webpage
	5	configuration title	The configuration title
	6	configuration bars	The configuration bars
<p>Please REBOOT to make the changes effective!</p> 			<ul style="list-style-type: none"> <li>◆ Every time making some changes, user should press the button to confirm and save the changes.</li> <li>◆ After pressing the button, the red <i>Please REBOOT to make the changes effective!</i> will appear to notice</li> </ul>

		user to reboot.
		To cancel the changes.
		Press it to reboot IP542N

## 7.3 Status

### 7.3.1 Basic

This webpage displays the basic status of your IP542N, including the information about product information, SIP account status, network status, VPN status, PC port status and system status.

Click **Refresh** button to refresh the status.

The screenshot displays the 'Status' page of an IP542N device. The page is organized into several sections, each with a title and a list of key-value pairs. At the top, there are navigation tabs for 'Status', 'SIP Account', 'Network', 'Phone', and 'Administration'. Below these, there are sub-tabs for 'Basic', 'DHCP', and 'Syslog'. The 'Basic' tab is selected, showing the following sections:

- Product Information:**
  - Product Name: IP542N
  - Internet(WAN) MAC Address: 00:21:F2:01:36:8D
  - PC(LAN) MAC Address: 00:21:F2:01:36:8C
  - Hardware Version: 1.0.1
  - Firmware Version: 1.2.4 (Hy0510213427)
  - DSP Version: D2.55
- SIP Account Status:**
  - Account 1 Registration State: Registered
  - Account 2 Registration State: Registered
  - Account 3 Registration State: Registered
  - Account 4 Registration State: Registered
- Network Status:**
  - Internet Port Status:**
    - Connection Status: Failed
    - Connection Type: DHCP
    - IP Address: 0.0.0.0
    - Subnet Mask: 0.0.0.0
    - Default Gateway: 0.0.0.0
    - Primary DNS: 202.96.134.33
    - Secondary DNS: 202.96.128.86
  - WIFI Status:**
    - Connection Status: ConnectedE3CALL\_SZ[00:21:F2:01:37:31]
    - Connection Type: DHCP
    - IP Address: 192.168.20.114
    - Subnet Mask: 255.255.255.0
    - Default Gateway: 192.168.20.1
    - Primary DNS: 202.96.134.33
    - Secondary DNS: 202.96.128.86
  - VPN Status:**
    - VPN Type: Disable
    - Virtual IP Address: 0.0.0.0
  - PC Port Status:**
    - Connection Status: Failed
    - Connection Type: Bridge
    - IP Address: 192.168.252.1
    - Subnet Mask: 255.255.255.0
- System Status:**
  - System Status:**
    - Current Time: May 11 16:31:20 2011
    - Elapsed Time: 0 D/0 H/5 M

At the bottom of the page, there is a 'Refresh' button.

## 7.3.2 DHCP

IP542N can be used as DHCP server, this page displays the status about DHCP server enable/disable, start IP address, end IP address and client lease time.

Click **Refresh** button to refresh status of DHCP server.

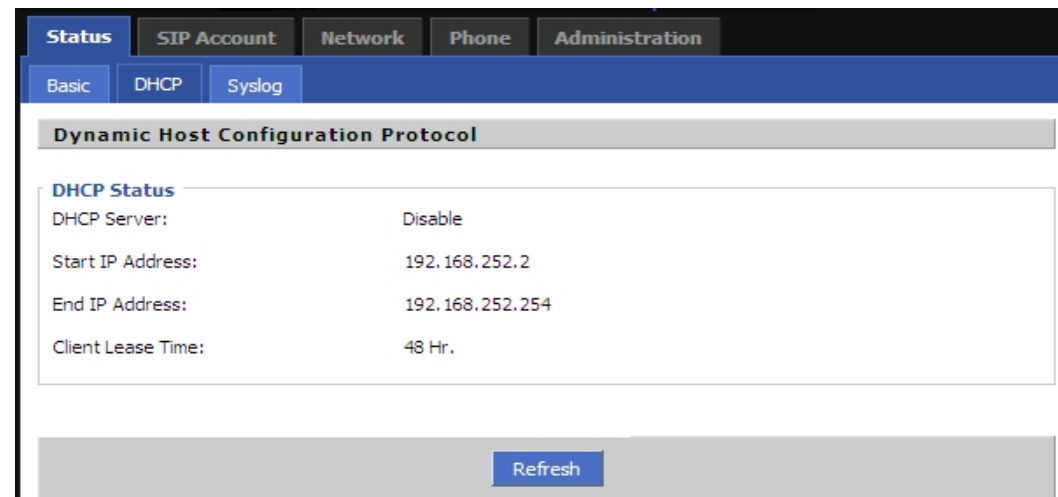

The screenshot shows the DHCP Status page. At the top, there are tabs for Status, SIP Account, Network, Phone, and Administration. Below these are sub-tabs for Basic, DHCP, and Syslog. The main content area is titled "Dynamic Host Configuration Protocol" and contains a "DHCP Status" section with the following information:

DHCP Server:	Disable
Start IP Address:	192.168.252.2
End IP Address:	192.168.252.254
Client Lease Time:	48 Hr.

At the bottom of the page, there is a "Refresh" button.

## 7.3.3 Syslog

This page displays the log of system.

User can press **Remove All** button to clear all information.

Click **Refresh** button to refresh syslog.

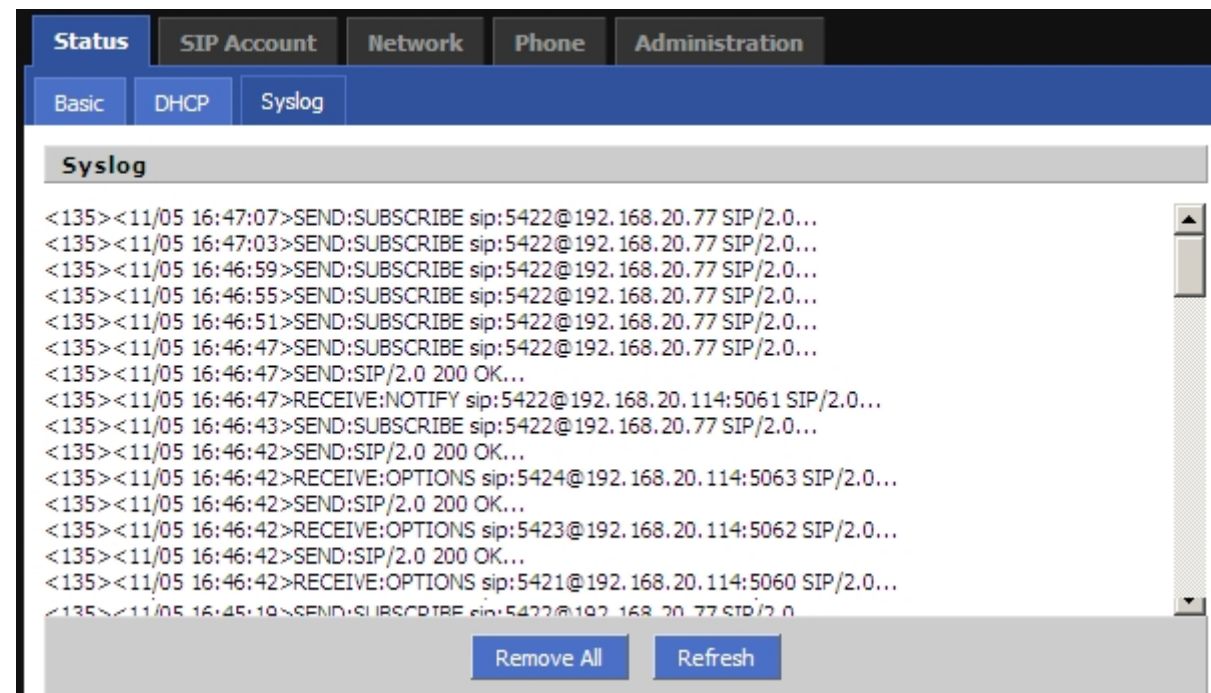

The screenshot shows the Syslog page. At the top, there are tabs for Status, SIP Account, Network, Phone, and Administration. Below these are sub-tabs for Basic, DHCP, and Syslog. The main content area is titled "Syslog" and contains a list of log entries:

```
<135><11/05 16:47:07>SEND:SUBSCRIBE sip:5422@192.168.20.77 SIP/2.0...
<135><11/05 16:47:03>SEND:SUBSCRIBE sip:5422@192.168.20.77 SIP/2.0...
<135><11/05 16:46:59>SEND:SUBSCRIBE sip:5422@192.168.20.77 SIP/2.0...
<135><11/05 16:46:55>SEND:SUBSCRIBE sip:5422@192.168.20.77 SIP/2.0...
<135><11/05 16:46:51>SEND:SUBSCRIBE sip:5422@192.168.20.77 SIP/2.0...
<135><11/05 16:46:47>SEND:SUBSCRIBE sip:5422@192.168.20.77 SIP/2.0...
<135><11/05 16:46:47>SEND:SIP/2.0 200 OK...
<135><11/05 16:46:47>RECEIVE:NOTIFY sip:5422@192.168.20.114:5061 SIP/2.0...
<135><11/05 16:46:43>SEND:SUBSCRIBE sip:5422@192.168.20.77 SIP/2.0...
<135><11/05 16:46:42>SEND:SIP/2.0 200 OK...
<135><11/05 16:46:42>RECEIVE:OPTIONS sip:5424@192.168.20.114:5063 SIP/2.0...
<135><11/05 16:46:42>SEND:SIP/2.0 200 OK...
<135><11/05 16:46:42>RECEIVE:OPTIONS sip:5423@192.168.20.114:5062 SIP/2.0...
<135><11/05 16:46:42>SEND:SIP/2.0 200 OK...
<135><11/05 16:46:42>RECEIVE:OPTIONS sip:5421@192.168.20.114:5060 SIP/2.0...
<135><11/05 16:45:19>SEND:SUBSCRIBE sip:5422@192.168.20.77 SIP/2.0...
```

At the bottom of the page, there are "Remove All" and "Refresh" buttons.

## 7.4 SIP Account



### 7.4.1 SIP Settings

#### 7.4.1.1 SIP Parameters

**SIP Parameters**

**SIP Parameters**

SIP T1:	<input type="text" value="500"/>	MS	Max Forward:	<input type="text" value="70"/>
SIP Reg User Agent Name:	<input type="text"/>		Max Auth:	<input type="text" value="2"/>
Mark All AVT Packets:	<input type="button" value="Enable"/>		RFC 2543 Call Hold:	<input type="button" value="Enable"/>
SRTP:	<input type="button" value="Disable"/>		SRTP Prefer Encryto:	<input type="button" value="AES_CM"/>

#### 7.4.1.2 NAT Traversal

Webpage	Field Name	Description								
<div style="border: 1px solid #ccc; padding: 5px;"> <p><b>NAT Traversal</b></p> <p><b>NAT Traversal</b></p> <table style="width: 100%; border-collapse: collapse;"> <tr> <td style="width: 30%;">NAT Traversal:</td> <td style="width: 20%;"><input type="button" value="Disable"/></td> <td style="width: 20%;">STUN Server IP:</td> <td style="width: 30%;"><input type="text" value="stun.fwdnet.net"/></td> </tr> <tr> <td>NAT Refresh Interval(sec):</td> <td><input type="text" value="60"/></td> <td>Port:</td> <td><input type="text" value="3478"/></td> </tr> </table> <p style="text-align: center;"> <input type="button" value="Save Settings"/> <input type="button" value="Cancel Changes"/> <input type="button" value="Reboot"/> </p> </div>	NAT Traversal:	<input type="button" value="Disable"/>	STUN Server IP:	<input type="text" value="stun.fwdnet.net"/>	NAT Refresh Interval(sec):	<input type="text" value="60"/>	Port:	<input type="text" value="3478"/>	NAT Traversal	If or not enable NAT. IP542N supports STUN traversal, choose “STUN” in the “NAT Traversal Mode” if you want traverse NAT/Firewall.
NAT Traversal:	<input type="button" value="Disable"/>	STUN Server IP:	<input type="text" value="stun.fwdnet.net"/>							
NAT Refresh Interval(sec):	<input type="text" value="60"/>	Port:	<input type="text" value="3478"/>							
	STUN Server IP	STUN server IP address, default is stun.fwdnet.net								
	NAT Refresh Interval (sec)	The interval to refresh								
	Port	STUN port								

### 7.4.2 Line 1

In this webpage, users can configuration the information about Line 1, including the following 4 parts: Basic, Audio Configuration,

Supplementary Service Subscription and Advanced.

Following is the description about that.

### 7.4.2.1 Basic

Set the basic information provided by your VOIP Service Provider, such as Phone Number, Account, password, SIP Proxy and so on.

Webpage	Field Name	Description
<p>The screenshot shows a configuration page with three main sections: 'Basic Setup' with dropdowns for 'Account Enable' (Enable) and 'Peer To Peer' (Enable), and 'Proxy DNS Type' (A Type); 'Proxy and Registration' with text boxes for 'Domain Name', 'SIP Server' (192.168.20.196), 'SIP Port' (5060), 'Outbound Proxy', and 'Outbound Port' (5060); and 'Subscriber Information' with text boxes for 'Display Name' (6521), 'Phone Number' (6521), 'Account' (6521), and 'Password' (masked with dots).</p>	Account Enable	If or not enable Account1
	Peer to Peer	If or not enable PEER to PEER. ◆ If enable, SIP-1 will not send register request to SIP server; but in Status/ SIP Account Status webpage, Status is Registered;
	Proxy DNS Type	Choose DNS type from A Type and DNS SRV.
	Use VPN	If or not enable VPN
	Domain Name	The domain of SIP Server
	SIP Server	The IP address of SIP Server
	SIP Port	The port which SIP Server supports for VOIP service, default is 5060
	Outbound Proxy	Outbound Proxy IP or domain name
	Outbound Port	Outbound Proxy's Service port
	Display Name	The number will display in LCD.
	Phone Number	Number of telephone provided by SIP Proxy
	Account	SIP account provided by SIP Proxy
	Password	SIP password provided by SIP Proxy

### 7.4.2.2 Audio Configuration

Select the audio Codec you want to use.

Webpage	Field Name	Description
---------	------------	-------------

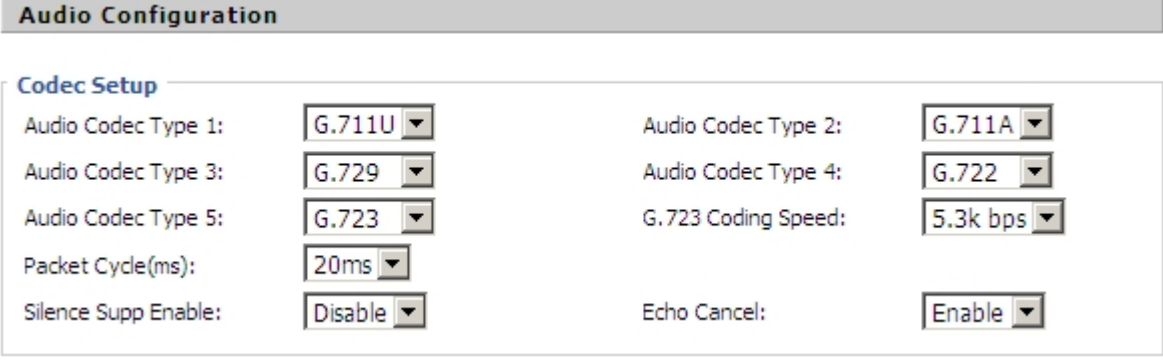
Webpage	Field Name	Description
	Audio Codec Type1	Choose the audio codec type from G.711U, G.711A, G.722, G.729, G.723
	Audio Codec Type2	Choose the audio codec type from G.711U, G.711A, G.722, G.729, G.723
	Audio Codec Type3	Choose the audio codec type from G.711U, G.711A, G.722, G.729, G.723
	Audio Codec Type4	Choose the audio codec type from G.711U, G.711A, G.722, G.729, G.723
	Audio Codec Type5	Choose the audio codec type from G.711U, G.711A, G.722, G.729, G.723
	G.723 Coding Speed	Choose the speed of G.723 from 5.3kbps and 6.3kbps
	Packet Cycle	The RTP packet cycle time
	Silence Supp Enable	If or not enable silence
	Echo Cancel	If or not enable echo cancel, default is enable.

### 7.4.2.3 Supplementary Services Subscription

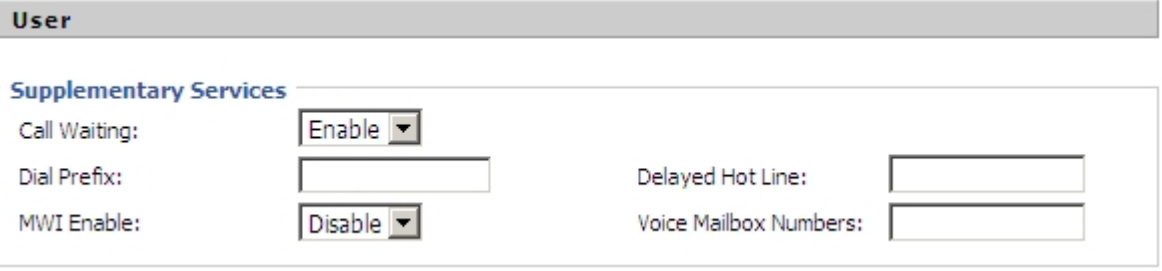
Webpage	Field Name	Description
	Call Waiting	If or not enable Call waiting.
	Call Pickup	If or not enable Call Pickup.
	Delayed Hot Line	Fill in the hotline number. Pickup handset or press Handsfree/headset button, IP542N will dial out the hotline number automatically.
	MWI Enable	If or not enable MWI (message waiting indicate).
	Voice Mailbox Numbers	Fill in the voice mailbox phone number

### 7.4.2.4 Advanced

Webpage	Field Name	Description
	Domain name Mode	If or not use domain name in the SIP URI

<div style="border: 1px solid black; padding: 5px;"> <p><b>Advanced</b></p> <p><b>Advanced Setup</b></p> <p>Domain Name Type: <input type="text" value="Disable"/></p> <p>Signal Port: <input type="text" value="5060"/></p> <p>RFC2833 Payload(&gt;=96): <input type="text" value="101"/></p> <p>RTP Port: <input type="text" value="0"/> (=0 auto select)</p> <p>Prack Enable: <input type="text" value="Disable"/></p> <p>Keep-alive Interval(10-60s): <input type="text" value="15"/></p> <p>Carry Port Information: <input type="text" value="Disable"/></p> <p>DTMF Type: <input type="text" value="RFC2833"/></p> <p>Register Refresh Interval(second): <input type="text" value="3600"/></p> <p>Cancel Message Enable: <input type="text" value="Disable"/></p> <p>SIP Ping Enable: <input type="text" value="Disable"/></p> </div>	Carry Port Information	If or not carry Port information in the SIP URI.
	Signal Port	The local port of SIP protocol, default is 5060
	DTMF Type	Choose the DTMF type from IN_band, RFC2833 and SIP INFO.
	RFC2833 Payload (>=96)	User can use the default setting
	Register Refresh Interval	The interval between two normal Register messages. You can use the default setting.
	RTP Port	Set the port to send RTP. IP Phone will select one idle port for RTP if you set "0", otherwise use the value user set.
	Cancel Message Enable	When you set enable, an unregistered message will be sent before registration, while you set disable, unregistered message will not be sent before registration. You should set the option for different Proxy.
	Prack Enable	If or not enable prack.
	SIP Ping Enable	If this option enable, IP Phone will send SIP-PING to Server periodically instead of sending hello packet. The send interval is Keep-alive interval.
	Keep-alive interval (10-60s)	The interval that IP Phone will send an empty packet to Proxy.

### 7.4.3 Line 2/3/4

The parameters of Line 2/3/4 are same as Line 1 except the value of **Account Enable** parameter.

## 7.5 Network

This including: basic, wireless, MAC Address Clone, VPN, DMZ and QoS, the picture like below:

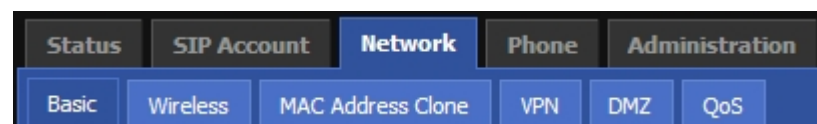

## 7.5.1 Basic

User can configuration the parameters of Internet Port, PC port and Network Address Server Settings (DHCP). The details are as follows:

### 7.5.1.1 Internet Port (WAN)

#### Static:

In static mode, user should fill in the values of IP Address, Subnet Mask, Default Gateway, Primary DNS and Second DNS got from your administration.

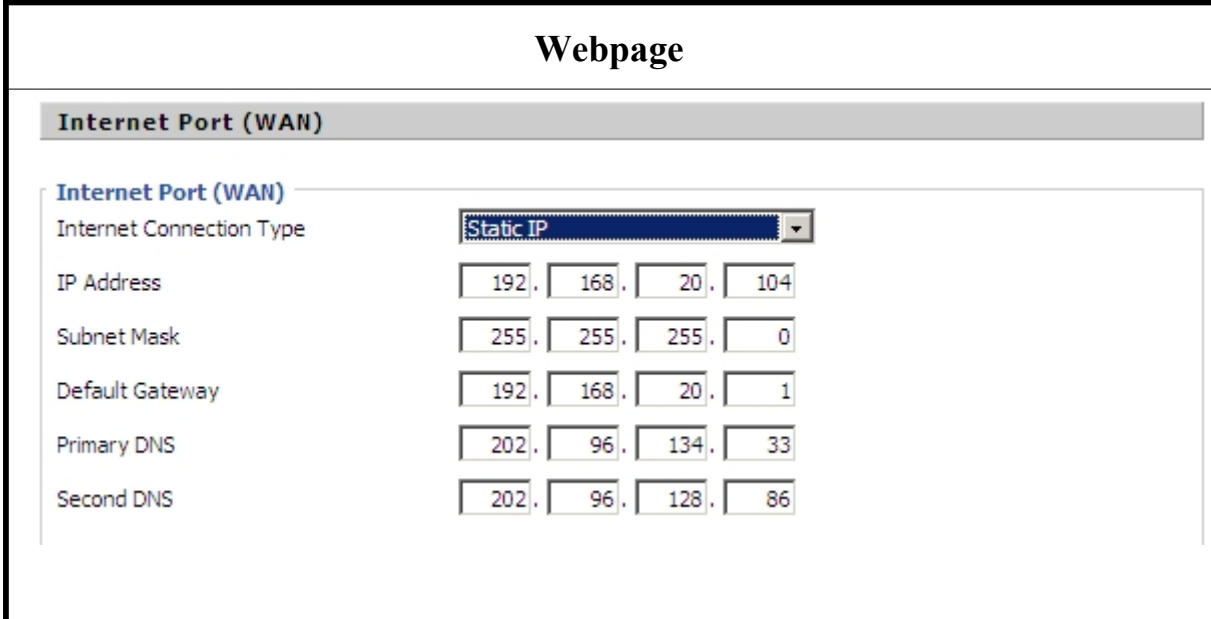
Webpage	Field Name	Description
	Internet Connection Type	Choose Static IP.
	IP Address	The IP address of Internet port
	Subnet Mask	The subnet mask of Internet port.
	Default Gateway	The default gateway of Internet port.
	Primary DNS	The primary DNS of Internet port.
	Second DNS	The second DNS of Internet port.

#### DHCP:

In DHCP mode, IP phone is a DHCP client.

IP phone will get the IP Address, Subnet Mask and Default Gateway from the DHCP server.

Webpage	Field Name	Description
	Internet Connection Type	Choose Automatic Configuration-DHCP.
	DNS type	Choose DNS type from Manual and Automatic

		<ul style="list-style-type: none"> <li>◆ In Manual: user should set the Primary DNS and Second DNS manually.</li> <li>◆ In Automatic: IP Phone will get the Primary DNS and Second DNS from DHCP Server automatically.</li> </ul>
--	--	---

### PPPoE:

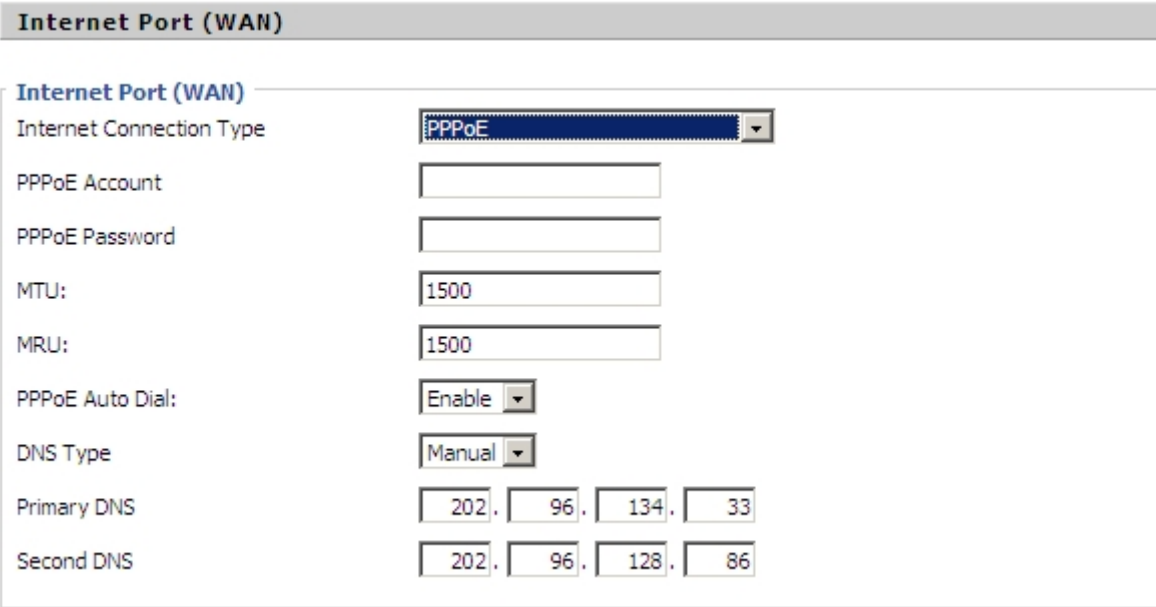
Webpage	Field Name	Description
	Internet Connection Type	Choose PPPoE.
	PPPoE Account	Fill in the PPPoE account which get from Internet Service Provider
	PPPoE Password	Fill in the PPPoE account get from Internet Service Provider
	PPPoE Auto-Dial	If or not enable PPPoE Auto-Dial.
	DNS Type	Choose DNS type from Manual and Automatic ◆ In Manual: user should set the Primary DNS and Second DNS manually. ◆ In Automatic: IP Phone will get the Primary DNS and Second DNS from DHCP Server automatically.
	Primary DNS	The primary DNS of Internet port.
	Second DNS	The second DNS of Internet port.

### 7.5.1.2 PC Port (LAN)

Webpage	Field Name	Description
	PC Port	Choose the PC port connection type from

PC Port(LAN)		Connection Type	disable, NAT and Bridge.
<b>PC Port(LAN)</b> PC Port Connection Type: <input type="text" value="NAT"/>		Local IP Address	Set the IP address of PC port. Efficient when user choose NAT.
Local IP Address: <input type="text" value="192."/> <input type="text" value="168."/> <input type="text" value="252."/> <input type="text" value="1"/>		Subnet Mask	Set the subnet mask of PC port. Efficient when user choose NAT.
Subnet Mask: <input type="text" value="255.255.255.0"/>			

### 7.5.1.3 Network Address Server Settings (DHCP)

Webpage	Field Name	Description
<b>Network Address Server Settings (DHCP)</b> Local DHCP Server: <input type="text" value="Enable"/> Start IP Address: <input type="text" value="192."/> <input type="text" value="168."/> <input type="text" value="252."/> <input type="text" value="2"/> Number of Address: <input type="text" value="253"/> Client Lease Time: <input type="text" value="48"/> Hr (0 means one day). Primary DNS: <input type="text" value="219."/> <input type="text" value="141."/> <input type="text" value="136."/> <input type="text" value="10"/> Second DNS: <input type="text" value="219."/> <input type="text" value="141."/> <input type="text" value="140."/> <input type="text" value="10"/>	Local DHCP Server	If or not enable DHCP Server. If PC port is not in NAT mode, user can not enable DHCP server.
	Start IP Address	The starting IP address which IP phone will attribute to clients. Note: The Network Sect of DHCP Server Start Address should be the same with the one that IP542N's PC port. Generally speaking, you can use the default setting.
	Number of Address	Number of IP address will distribute to clients.
	Client Lease Time	The interval of DHCP will send request to continue in period of validity. Unit is hour.
	Primary DNS	Primary DNS that DHCP Server will distribute. You can use the default setting.
	Secondary DNS	Secondary DNS that DHCP Server will distribute. You can use the default setting.

## 7.5.2 Wireless

### 7.5.2.1 Wireless Settings

#### Static:

In static mode, user should fill in the values of IP Address, Subnet Mask, Default Gateway, Primary DNS and Second DNS got from your administration.

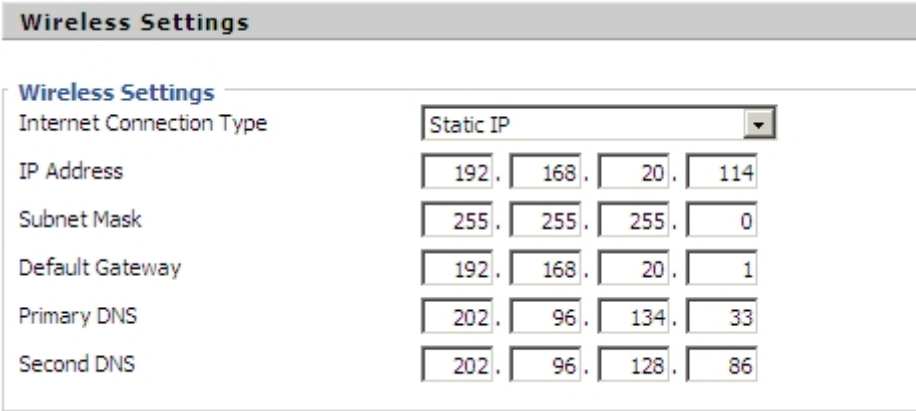
Webpage	Field Name	Description
 <p>The screenshot shows the 'Wireless Settings' page. Under 'Wireless Settings', the 'Internet Connection Type' is set to 'Static IP'. Below this, there are input fields for IP Address (192, 168, 20, 114), Subnet Mask (255, 255, 255, 0), Default Gateway (192, 168, 20, 1), Primary DNS (202, 96, 134, 33), and Second DNS (202, 96, 128, 86).</p>	Internet Connection Type	Choose Static IP.
	IP Address	The IP address of Internet port
	Subnet Mask	The subnet mask of Internet port.
	Default Gateway	The default gateway of Internet port.
	Primary DNS	The primary DNS of Internet port.
	Second DNS	The second DNS of Internet port.

## DHCP:

In DHCP mode, IP phone is a DHCP client.

IP phone will get the IP Address, Subnet Mask and Default Gateway from the DHCP server from AP.

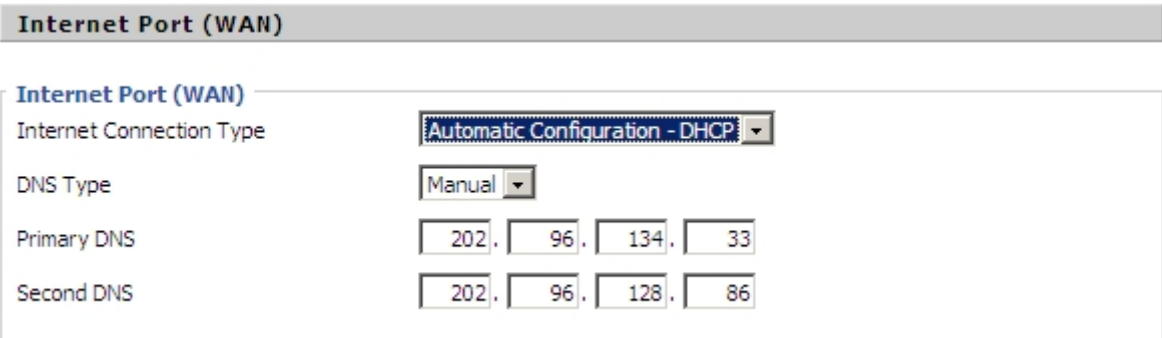
Webpage	Field Name	Description
 <p>The screenshot shows the 'Internet Port (WAN)' page. Under 'Internet Port (WAN)', the 'Internet Connection Type' is set to 'Automatic Configuration - DHCP'. Below this, there is a 'DNS Type' dropdown set to 'Manual'. There are also input fields for Primary DNS (202, 96, 134, 33) and Second DNS (202, 96, 128, 86).</p>	Internet Connection Type	Choose Automatic Configuration-DHCP.
	DNS type	Choose DNS type from Manual and Automatic <ul style="list-style-type: none"> <li>◆ In Manual: user should set the Primary DNS and Second DNS manually.</li> <li>◆ In Automatic: IP Phone will get the Primary DNS and Second DNS from DHCP Server automatically.</li> </ul>

### 7.5.2.2 Wireless Connection

Webpage	Field Name	Description
	Connection Status	Display the current connection status, and the name of connected AP appear in the brackets if the wireless is connected.

Wireless Connection																													
<div style="border: 1px solid gray; padding: 5px;"> <p><b>Wireless Connection</b></p> <p>Connection Status: Connected (AP: E3CALL_SZ[00:21:F2:01:37:31])</p> <table border="1" style="width: 100%; border-collapse: collapse;"> <thead> <tr> <th>SSID</th> <th>Authentication</th> <th>Encryption</th> <th>Status</th> </tr> </thead> <tbody> <tr> <td>E3CALL_SZ</td> <td>WPA1PSK/WPA2PSK</td> <td>TKIP/AES</td> <td style="text-align: center;">✓</td> </tr> <tr> <td>anyway</td> <td>OPEN</td> <td>NONE</td> <td style="text-align: center;">📶</td> </tr> <tr> <td>ChinaNet-zzXM</td> <td>WPAPSK</td> <td>TKIP</td> <td style="text-align: center;">📶</td> </tr> <tr> <td>T</td> <td>home</td> <td>TKIP/AES</td> <td style="text-align: center;">📶</td> </tr> </tbody> </table> <p style="margin-top: 5px;"> <input type="button" value="Connect"/> <input type="button" value="Refresh"/> </p> </div>	SSID	Authentication	Encryption	Status	E3CALL_SZ	WPA1PSK/WPA2PSK	TKIP/AES	✓	anyway	OPEN	NONE	📶	ChinaNet-zzXM	WPAPSK	TKIP	📶	T	home	TKIP/AES	📶	<table border="1" style="width: 100%; border-collapse: collapse;"> <tr> <td style="width: 20%;">SSID</td> <td>The SSID name of all searched AP.</td> </tr> <tr> <td>Authentication</td> <td>Display the authentication type of the AP</td> </tr> <tr> <td>Encryption</td> <td>Display the encryption type of the AP</td> </tr> <tr> <td>Status</td> <td> <p>Display the status of the AP.</p> <p>The icon  stands for the IP542N have connected to the AP.</p> <p>The icon  stands for the signal strength of the AP.</p> </td> </tr> </table>	SSID	The SSID name of all searched AP.	Authentication	Display the authentication type of the AP	Encryption	Display the encryption type of the AP	Status	<p>Display the status of the AP.</p> <p>The icon  stands for the IP542N have connected to the AP.</p> <p>The icon  stands for the signal strength of the AP.</p>
SSID	Authentication	Encryption	Status																										
E3CALL_SZ	WPA1PSK/WPA2PSK	TKIP/AES	✓																										
anyway	OPEN	NONE	📶																										
ChinaNet-zzXM	WPAPSK	TKIP	📶																										
T	home	TKIP/AES	📶																										
SSID	The SSID name of all searched AP.																												
Authentication	Display the authentication type of the AP																												
Encryption	Display the encryption type of the AP																												
Status	<p>Display the status of the AP.</p> <p>The icon  stands for the IP542N have connected to the AP.</p> <p>The icon  stands for the signal strength of the AP.</p>																												

### 7.5.3 MAC Address Clone

MAC is the hardware address of network equipment. Sometimes, network providers may bind network account with the network equipment's MAC address. So you may not pass the provider's authentication when you use a new IP542N. In this case, you can use MAC Clone to copy your PC's MAC address to IP542N's Internet port.

MAC is an important parameter for network equipments, so you should make sure that the MAC is right, in order to prevent to make IP542N unusable.

You can login IP542N's Web via PC port if you are incautious to make it wrong. And then cloning the right MAC or resume the default settings.

Webpage	Description
<div style="border: 1px solid gray; padding: 5px;"> <p style="text-align: center;"><b>MAC Address Clone</b></p> <div style="border: 1px solid gray; padding: 5px; margin-top: 5px;"> <p><b>MAC Clone</b></p> <p>Clone WAN MAC: <input style="width: 20px;" type="text" value="00"/> : <input style="width: 20px;" type="text" value="00"/> : <input style="width: 20px;" type="text" value="00"/> : <input style="width: 20px;" type="text" value="00"/> : <input style="width: 20px;" type="text" value="00"/> : <input style="width: 20px;" type="text" value="00"/></p> <p style="text-align: center;"><input type="button" value="Get Current PC MAC Address"/></p> <p style="text-align: center; margin-top: 10px;"> <input type="button" value="Save Settings"/> <input type="button" value="Clear"/> <input type="button" value="Reboot"/> </p> </div> </div>	<p>Step 1 Press <input type="button" value="Get Current PC MAC Address"/> button to get the PC's MAC address</p> <p>Step 2 Press <input type="button" value="Save Settings"/> to save the changes</p> <p>Step 3. Press <input type="button" value="Clear"/> to cancel MAC address clone.</p>

	Step 4. Press Reboot to reboot IP542N.
--	--

### 7.5.4 VPN

A Virtual Private Network (VPN) is the extension of a private network that encompasses links across shared or public networks like the Internet. In short, by VPN technology, you can send data between two computers across a shared or public network in a manner that emulates the properties of a point-to-point private link.

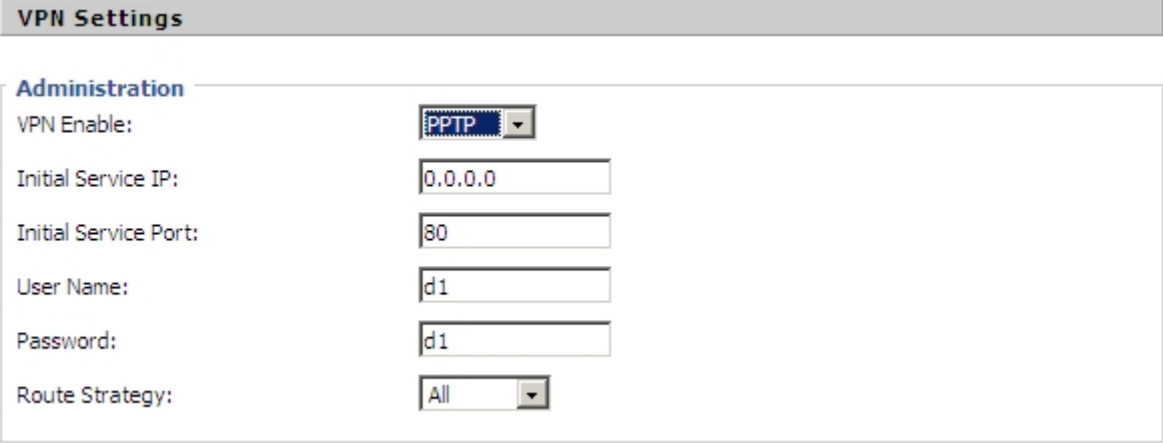
Webpage	Field Name	Description
	VPN Enable	If or not enable VPN. And user can choose the VPN mode from PPTP and L2TP.
	Initial Service IP	VPN server IP address
	Initial Service Port	VPN server port
	User Name	The user name for authentication
	Password	Password for authentication
	Route Strategy	Choose route mode from all or SIP

### 7.5.5 DMZ

IP542N provides a facility DMZ Host that maps ALL unsolicited data on any protocol to a single host in the LAN. Regular web surfing and other such Internet activities from other clients will continue to work without inappropriate interruption. DMZ Host allows a defined internal user to be totally exposed to the Internet, which usually helps some special applications such as Netmeeting or Internet Games etc.

Webpage	Field Name	Description
---------	------------	-------------

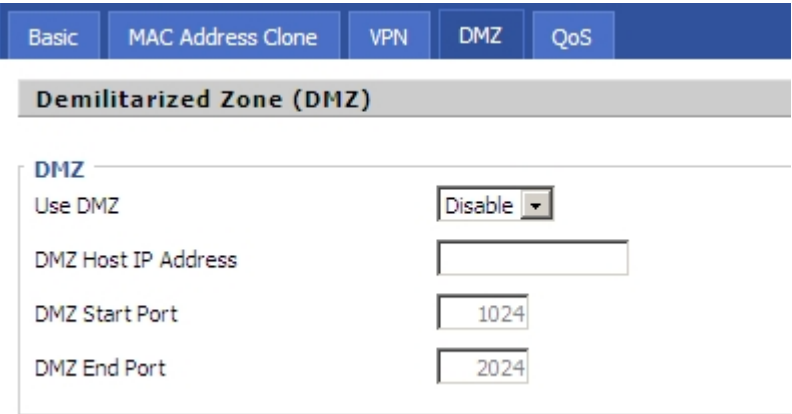
	Use DMZ	If or not enable DMZ
	DMZ Host IP Address	set the IP address of DMZ host
	DMZ Start Port	set the start port of DMZ host
	DMZ End Port	set the end port of DMZ host
	<p>For example, the DMZ computer's IP is "192.168.1.2", "DMZ start port" and "DMZ end port" is 20 and 1023. The DMZ function is that DMZ computer can get the requests from the ports (20 to 1023) of IP542N's Internet port.</p>	

## 7.5.6 QoS

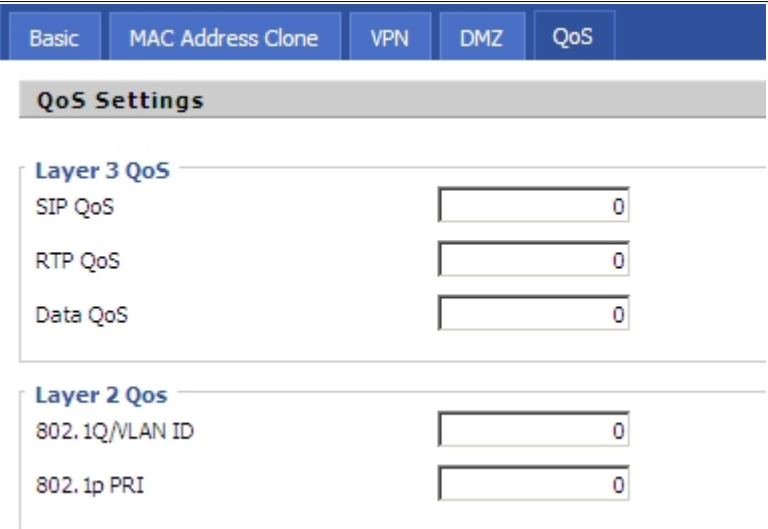
Webpage	Description
	<p>Some ISP supply QoS services. The QoS services can make the best of improving the quality of Voice application. You can get the settings from the ISP if they supply QoS services. Please connect with them if you need it.</p>

## 7.6 Phone

User can configuration volumes, call forward, dial plan, phonebook, call log and so on.

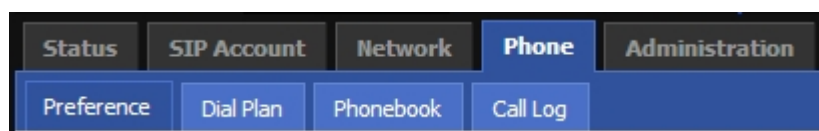

## 7.6.1 Preference

User can configuration the value of ring volume, Handsfree volume, handset volume and so on.

### 7.6.1.1 Preference

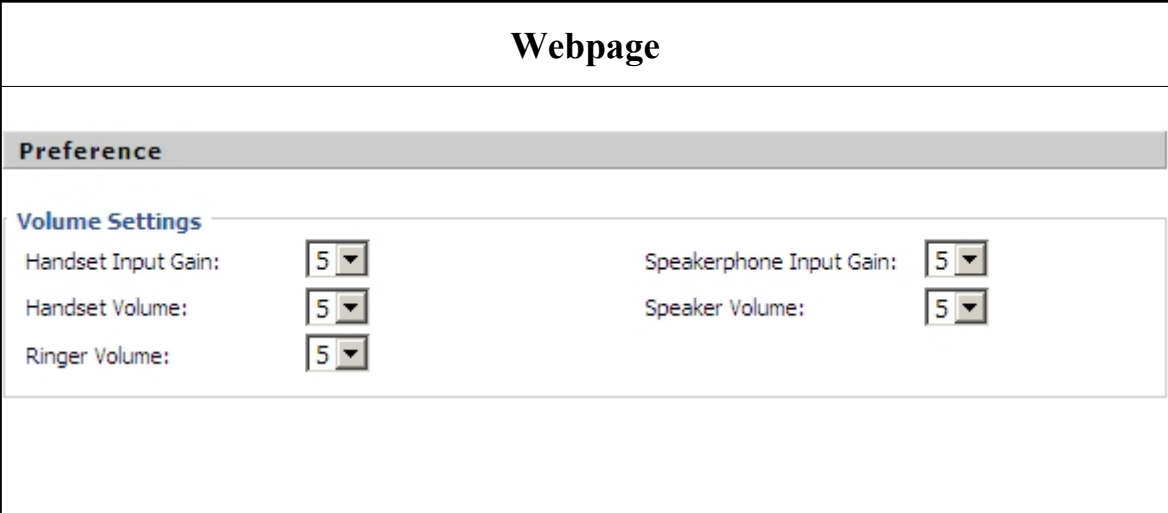
Webpage	Field Name	Description
 <p><b>Preference</b></p> <p><b>Volume Settings</b></p> <p>Handset Input Gain: <input type="text" value="5"/> Speakerphone Input Gain: <input type="text" value="5"/></p> <p>Handset Volume: <input type="text" value="5"/> Speaker Volume: <input type="text" value="5"/></p> <p>Ringer Volume: <input type="text" value="5"/></p>	Handset Input Gain	Adjust the handset input gain from 0-7
	Handset Volume Gain	Adjust the output gain from 0-7
	Handsfree Input Gain	Adjust the Handsfree input gain from 0-7
	Handsfree Volume	Adjust the Handsfree volume form 0-7
	Ringer Volume	Adjust the ringer volume form 0-7.

### 7.6.1.2 Regional

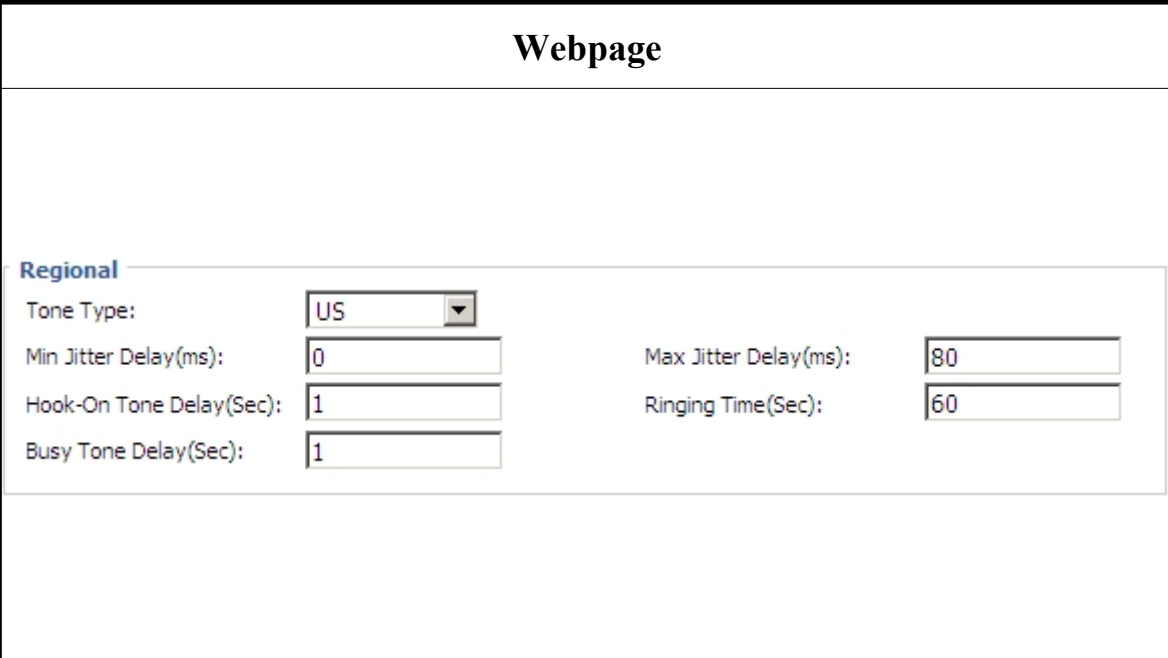
Webpage	Field Name	Description
 <p><b>Regional</b></p> <p>Tone Type: <input type="text" value="US"/></p> <p>Min Jitter Delay(ms): <input type="text" value="0"/> Max Jitter Delay(ms): <input type="text" value="80"/></p> <p>Hook-On Tone Delay(Sec): <input type="text" value="1"/> Ringing Time(Sec): <input type="text" value="60"/></p> <p>Busy Tone Delay(Sec): <input type="text" value="1"/></p>	Tone Type	Choose tone type form China, US, Hong Kong and KR.
	Min Jitter Delay (ms)	The Min value of IP542N's jitter delay, IP542N is an adaptive jitter mechanism.
	Max Jitter Delay (ms)	The Max value of IP542N's jitter delay, IP542N is an adaptive jitter mechanism.
	Hook-On Tone Delay (sec)	How long IP542N will delay to sound hook-on tone when call party end call.
	Ringing Time(Sec)	How long IP542N will ring
	Busy Tone Delay (Sec)	

### 7.6.1.3 Call Forward

Webpage	Field Name	Description
<p><b>Call Forward</b></p> <p>Cfwd All Dest: <input type="text"/> Cfwd Busy Dest: <input type="text"/></p> <p>Cfwd No Ans Dest: <input type="text"/> Cfwd No Ans Delay: <input type="text" value="20"/></p>	Cfwd All Dest	The phone number which will be forwarded to. IP Phone will forward all calls to the phone number immediately when there is an incoming call.
	Cfwd Busy Dest	The phone number which will be forwarded to when line is busy.
	Cfwd No Ans Dest	The phone number which will be forwarded to when there's no answer at your phone.
	Cfwd No Ans Delay	The seconds to delay forwarding calls, if there is no answer at your phone.

### 7.6.1.4 Miscellaneous

Webpage	Field Name	Description
<p><b>Miscellaneous</b></p> <p>Auto Answer: <input type="text" value="Disable"/> Dial Time Out: <input type="text" value="5"/></p> <p>Call Immediately Key: <input type="text" value="#"/> ICMP Ping: <input type="text" value="Disable"/></p>	Auto Answer	If or not enable auto answer. If enable, IP542N will auto answer all incoming call immediately.
	Dial Time Out	How long IP542N to sound dial out tone when IP542N dialing number.
	Call Immediately Key	Choose call immediately key form * or #.
	ICMP Ping	If or not enable ICMP Ping. If enable this option, IP542N will ping the SIP Server every interval time, otherwise, It will send "hello" empty packet to the SIP Server.

## 7.6.2 Dial Plan

### 7.6.2.1 Parameters and Settings

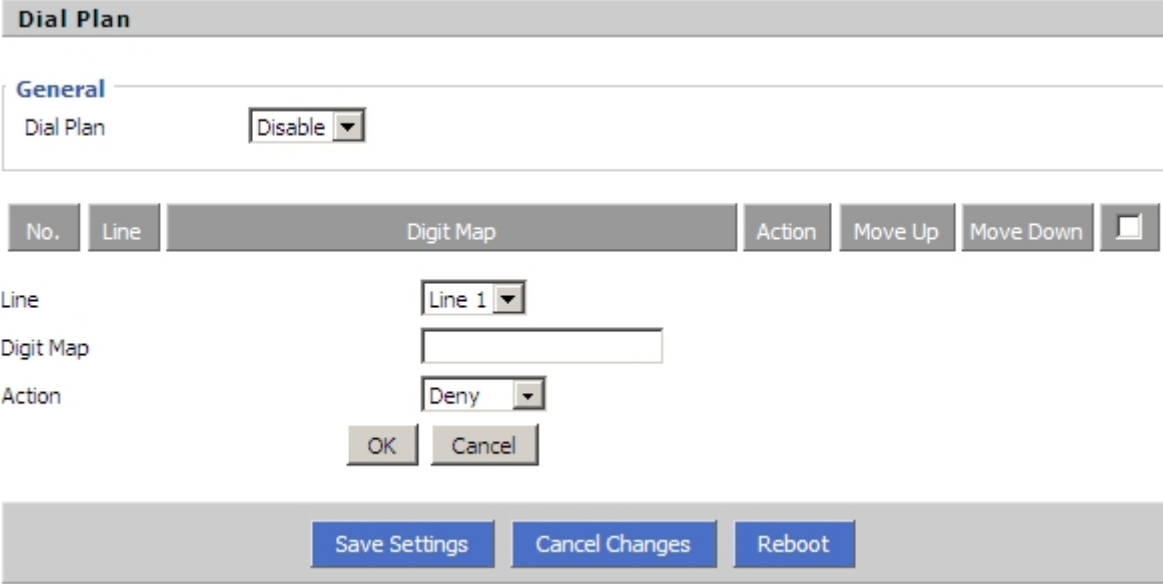
Webpage	Field Name	Description
 <p style="text-align: center;">Picture 1</p>	Dial Plan	If or not enable dial rule.
	Line	Choose the call mode from line1, line2, line3, line4 and line5.
	Digit Map	Fill in the sequence used to match input number
		The syntactic, please refer to the following <b>Dial Plan Syntactic</b>
	Action	Choose the dial plan mode from Deny and Dial Out. <b>Deny</b> means IP542N will reject the matched number, while <b>Dial Out</b> means IP542N allow dial out the matched number.
	Move Up	Press it to move up.
	Move Down	Press it to move down.

**Dial Plan**

**General**

Dial Plan Disable ▾

No.	Line	Digit Map	Action	Move Up	Move Down	
1	Line1	<9:010>2010110	Dial Out	⬆	⬇	<input type="checkbox"/>
2	Line2	<5,:><:241333>8101	Dial Out	⬆	⬇	<input type="checkbox"/>
3	Line3	<[4-6]:>22x<:333>	Dial Out	⬆	⬇	<input type="checkbox"/>
4	Line4	<9,8,:>711	Dial Out	⬆	⬇	<input type="checkbox"/>
5	Line5	<[2-5],:5>622.	Deny	⬆	⬇	<input type="checkbox"/>

Line Line 1 ▾

Digit Map

Action Deny ▾

OK Cancel

Save Settings Cancel Changes Reboot

Picture 2

### Steps :

#### Adding one dial plan:

Step 1. Enable Dial Plan

Step 2. Click **Add** button, and the configuration table like Picture 1 will appear

Step 3. Fill in the value of parameters.

Step 4. Press **OK** button to end configuration.

Step 5. Press **Save Settings** button to save changes.

#### Editing one dial plan:

Step 1. Enable Dial plan

Step 2. Choose one dial plan

Step 3. Click **Edit** button, and the configuration table like Picture 2 will appear

Step 4. Change the value of parameters.

Step 5. Press **OK** button to end configuration.

Step 6. Press **Save Settings** button to save changes.

#### Deleting one dial plan:

Step 1. Enable Dial plan

Step 2. Choose one dial plan

Step 3. Click **Delete** button to delete the dial plan

## 7.6.2.2 Dial Plan Syntactic

No.	String	Description
1	0 1 2 3 4 5 6 7 8 9 * #	Legal characters
2	X	Lowercase letter x stands for one legal character
3	[sequence]	To match one character form sequence. For example: <ul style="list-style-type: none"> <li>[0-9]: match one digit form 0 to 9</li> <li>[23-5*]: match one character from 2 or 3 or 4 or 5 or *</li> </ul>
4	x.	Match to $x^0, x^1, x^2, x^3, \dots, x^n$ For example: "01.": can match "0", "01", "011", "0111", ....., "01111..."
5	<dialed: substituted>	Replace dialed with substituted. For example: <8:1650>123456: input is "85551212", output is"16505551212"
6	x,y	Make outside dial tone after dialing "x", stop until dialing character "y" For example: "9,1xxxxxxxxxx":IP542N make outside dial tone after inputting "9", stop tone until inputting "1" "9,8,010x": make outside dial tone after inputting "9", stop tone until inputting "0"
7	T	Set the delayed time. For example: "<9:111>T2": IP542N will dial out the matched number "111" after 2 seconds.

## 7.6.2.3 Example

### Dial Plan

#### General

Dial Plan

Enable

No.	Line	Digit Map	Action	Move Up	Move Down	
1	Line1	<:010>#12<#:%23>2	Dial Out	▲	▼	<input type="checkbox"/>
2	Line2	<5,:><:241333>8101	Dial Out	▲	▼	<input type="checkbox"/>
3	Line3	<[4-5]:>22xxxx<:333>	Dial Out	▲	▼	<input type="checkbox"/>
4	Line4	<2-3,:5:>622.	Dial Out	▲	▼	<input type="checkbox"/>
5	Line5	777x.8	Deny	▲	▼	<input type="checkbox"/>

Example 1

Example 2

Example 5

Example 3

Example 4

### 1. Example 1

If user dials **#12#2**, IP542N will call **010#12%232** immediately.

### 2. Example 2

If user dials **5,8101**, IP542N will call **2413338101**

immediately,

And IP542N will make outside dial tone after inputting “5”, stop tone until inputting “8”.

### 3. Example 3

If user dials **422xxxx** or **522xxxx**, IP542N will call **22xxxx333** immediately.

### 4. Example 4

If user dials **2,622** or **2,6222** or **2,62222** or **2.62222<sup>2</sup>** or **3.62222<sup>2</sup>**,

IP542N will call **5622** or **56222** or **562222** or **562222<sup>2</sup>** or **562222<sup>2</sup>** immediately.

And IP542N will make outside dial tone after inputting

“2” or “3”, stop tone until inputting “6”.

### 5. Example 5

If user dials  $777x8$ , IP542N will reject the phone number out.

## 7.6.3 Phone Book

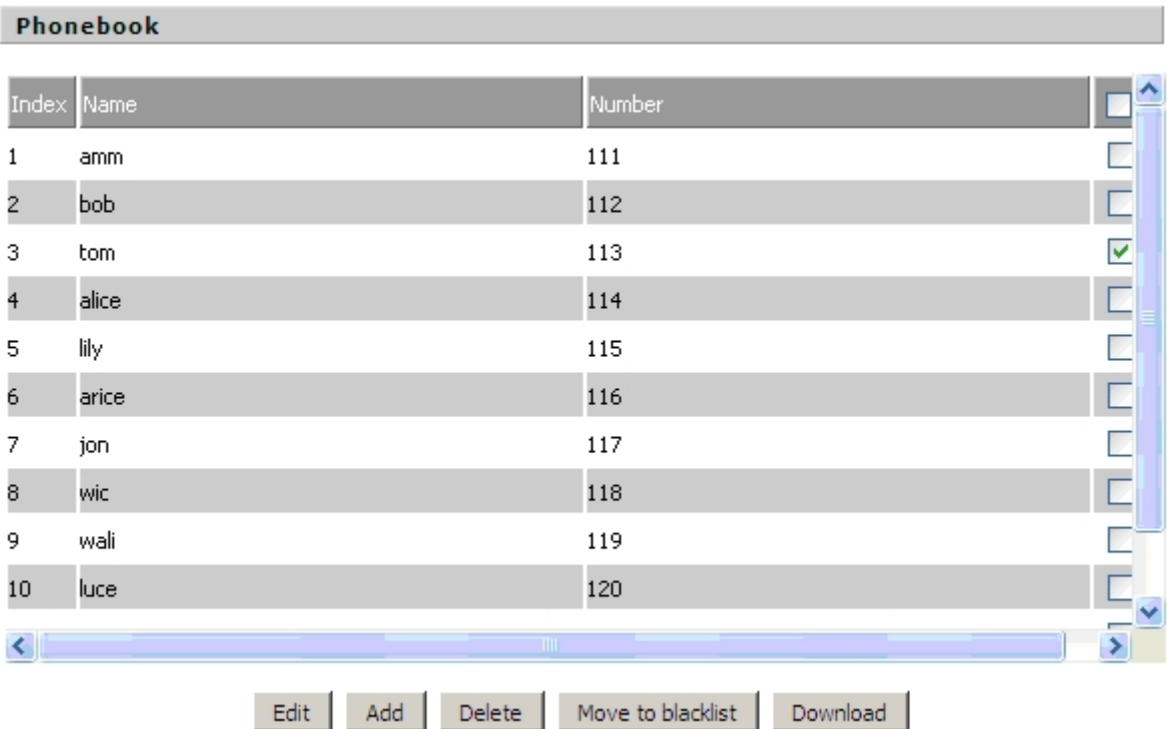
Webpage	Field Name	Description
 <p>Picture 1</p>	Name	Input the name
 <p>Picture 2</p>	<p><b>Steps :</b></p> <p><b>Adding one phone book:</b></p> <p>Step 1. Click <b>Add</b> button, and the configuration table like Picture 1 will appear</p> <p>Step 2. Fill in the value of parameters.</p> <p>Step 3. Press <b>OK</b> button to end configuration.</p> <p>Step 4. Press <b>Save Settings</b> button to save changes.</p> <p><b>Editing one phone book:</b></p> <p>Step 1. Choose one phone book</p> <p>Step 2. Click <b>Edit</b> button, and the configuration table like</p>	

Name

Number

Picture 3

---

**Phonebook**

Index	Name	Number	
1	amm	111	<input type="checkbox"/>
2	bob	112	<input type="checkbox"/>
3	tom	113	<input checked="" type="checkbox"/>
4	alice	114	<input type="checkbox"/>
5	lily	115	<input type="checkbox"/>
6	arice	116	<input type="checkbox"/>
7	jon	117	<input type="checkbox"/>
8	wic	118	<input type="checkbox"/>
9	wali	119	<input type="checkbox"/>
10	luce	120	<input type="checkbox"/>

**Black List**

Index	Name	Number	
1	k	122	<input type="checkbox"/>

Picture 4

Picture 3 will appear

Step 3. Change the value of parameters.

Step 4. Press **OK** button to end configuration.

Step 5. Press **Save Settings** button to save changes.

**Deleting one phone book:**

Step 1. Choose one phone book

Step 2. Click **Delete** button to delete the phone book

**Move one phone book to Black list:**

Step 1. Choose one phone book

Step 2. Click **Move to blacklist** button to delete the phone book

**7.6.3.1 Black List**

Webpage	Field Name	Description
<p>Name <input type="text"/></p> <p>Number <input type="text"/></p> <p><input type="button" value="OK"/> <input type="button" value="Cancel"/></p> <p style="text-align: center;">Picture 1</p>	Name	Input the name
	Number	Input the phone number

Black List			
Index	Name	Number	<input type="checkbox"/>
1	k	122	<input type="checkbox"/>
2	w	123	<input checked="" type="checkbox"/>
3	q	124	<input type="checkbox"/>
4	r	125	<input type="checkbox"/>

Name

Number

Picture 2

**Steps :**

**Adding one Black List:**

Step 1. Click **Add** button, then the configuration table like

Picture 1 will appear

Step 2. Fill in the value of parameters.

Step 3. Press **OK** button to end configuration.

Step 4. Press **Save Settings** button to save changes.

**Editing one Black List:**

Step 1. Choose one black list

Step 2. Click **Edit** button, and the configuration table like

Picture 2 will appear

Step 3. Change the value of parameters.

Step 4. Press **OK** button to end configuration.

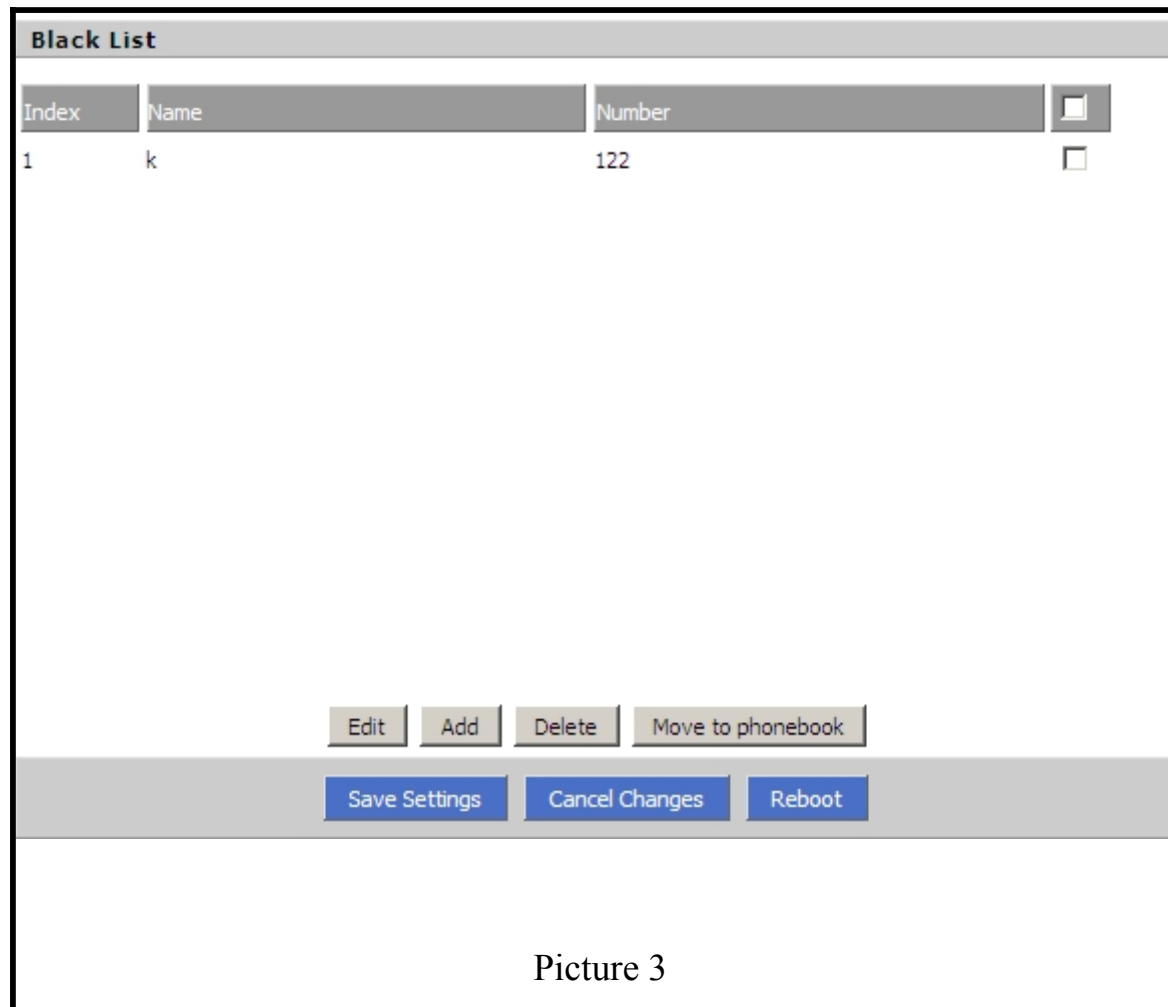

Step 5. Press **Save Settings** button to save changes.

#### **Deleting one Black List:**

Step 1. Choose one black list

Step 2. Click **Delete** button to delete the black list

#### **Moving one Black List to phonebook:**

Step 1. Choose one black list

Step 2. Click  button to move the black list to the phonebook

## **7.6.4 Call Log**

To view the call log information such as redial list (incoming call), answered call and missed call.

### 7.6.4.1 Redial List

Redial List					
Index	Name	Number	Start Time	Duration	<input type="checkbox"/>
1	3503	3503	05/11 18:00	00:00:02	<input type="checkbox"/>
2	3503	3503	01/01 00:01	00:00:39	<input type="checkbox"/>
3	6223	6223	05/11 17:51	00:02:26	<input type="checkbox"/>
4	3503	3503	01/01 00:00	00:00:55	<input type="checkbox"/>
5	6223	6223	05/11 17:21	00:00:07	<input type="checkbox"/>
6	6223	6223	05/11 17:21	00:00:08	<input type="checkbox"/>
7	6	6	05/11 17:20	00:00:01	<input type="checkbox"/>
8	6223	6223	05/11 16:09	00:00:03	<input type="checkbox"/>

### 7.6.4.2 Answered Calls

Answered Calls					
Index	Name	Number	Start Time	Duration	
1	222	222	04/19 12:29	00:00:18	
2	111	111	04/19 12:20	00:00:39	
3	222	222	04/19 12:19	00:00:12	
4	222	222	04/19 12:17	00:00:08	
5	111	111	04/19 11:55	00:04:00	
6	111	111	04/19 11:52	00:02:59	
7	111	111	04/19 11:11	00:01:01	
8	111	111	04/19 10:52	00:00:18	
9	111	111	04/19 10:52	00:00:05	
10	111	111	04/19 10:51	00:00:20	
11	6526	6526	04/18 12:14	00:00:04	
12	6526	6526	04/18 12:07	00:00:06	
13	6526	6526	04/18 12:00	00:00:06	

### 7.6.4.3 Missed Call

Missed Calls				
Index	Name	Number	Start Time	Duration
1	456	456	03/25 19:06	00:00:01
2	456	456	03/25 19:06	00:00:00
3	456	456	03/25 19:05	00:00:01
4	456	456	03/25 19:05	00:00:01
5	456	456	03/25 19:05	00:00:01

## 7.7 Administration

Use can manage the IP542N in these six webpage; you can configuration the Time/Date, password, web access, system log and so on.

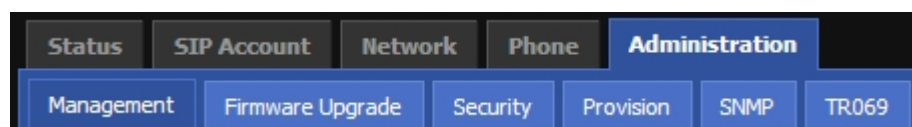

### 7.7.1 Management

You can configuration the value of Time/Date, password, web access, and system log and so on.

#### 7.7.1.1 Time/Date

Webpage	Field Name	Description
	NTP Server	Fill in the NTP server IP address or Domain name
	Time Zone	Choose the time zone
	Manual Time	Adjust time by manual
	Alarm Enable	If or not enable alarm
	Alarm Time	Set alarm time
	Daylight Saving Time	If or not enable daylight saving time.
	Offset	Offset time, “-60” means advancing 60miniter, “60” means delaying 60minite
	Start Month	Choose starting month
	Start Day of Week	Choose starting day

	Start Day of Week Last in Month	Choose starting week
	Start Hour of Day	Choose starting hour
	Stop Month	Choose stopping month
	Stop Day of Week	Choose stopping day
	Stop Day of Week Last in Month	Choose stopping week
	Stop Hour of Day	Choose stopping the function hour
<p>Alarm Enable: <input type="text" value="Enable"/></p> <p>Alarm Time: <input type="text" value="17"/> : <input type="text" value="40"/> : <input type="text" value="00"/></p> <p style="text-align: center;">Picture 1</p>	<p><b>Steps:</b></p> <p><b>Alarm:</b></p> <p>Step 1. Enable alarm</p> <p>Step 2. Set alarm time, like Picture 1.</p> <p>Step 3. Press <b>Save Settings</b> button to save changes and then press <b>Reboot</b> button to active changes.</p> <p><b>Daylight Saving Time:</b></p> <p>Step 1. Enable Daylight Saving Time.</p> <p>Step 2. Set value of offset, like Picture 2</p> <p>Step 3: Set starting Month/Week/Day/Hour in <b>Start Month/Start Day of Week Last in Month/Start Day of Week/Start Hour of Day</b>, analogously set stopping Month/Week/Day/Hour in <b>Stop Month/Stop Day of Week Last in Month/Stop Day of Week/Stop Hour of Day</b>.</p> <p>Step 5. Press <b>Saving Settings</b> button to save and press <b>Reboot</b> button to active changes.</p>	
<p>Daylight Saving Time <input type="text" value="Enable"/></p> <p>Offset <input type="text" value="60"/> Min.</p> <p>Start Month <input type="text" value="March"/></p> <p>Start Day of Week <input type="text" value="Sunday"/></p> <p>Start Day of Week Last in Month <input type="text" value="Last in Month"/></p> <p>Start Hour of Day <input type="text" value="2"/></p> <p>Stop Month <input type="text" value="October"/></p> <p>Stop Day of Week <input type="text" value="Sunday"/></p> <p>Stop Day of Week Last in Month <input type="text" value="Last in Month"/></p> <p>Stop Hour of Day <input type="text" value="3"/></p> <p style="text-align: center;">Picture 2</p>		

--	--

**7.7.1.2 Password Reset**

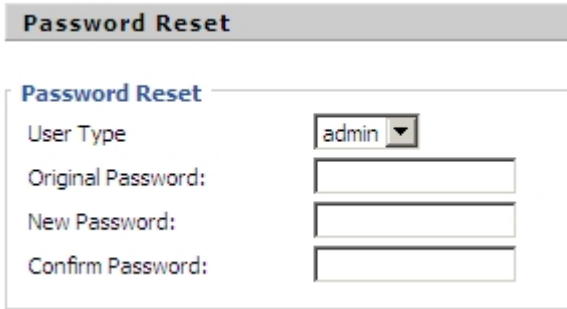

Webpage	Field Name	Description
	User Type	Choose the user type from admin and user.
	Original Password	Input original password
	New Password	Input the new password
	Password Confirm	Input the new password again
	<p><b>Change the password of admin mode:</b></p> <p><b>Steps:</b></p> <p>Step 1. Choose the admin from the drop-down list.</p> <p>Step 2. Input original password, default setting is null.</p> <p>Step 3. Input a new password twice time in <b>New Password</b> and <b>Confirm Password</b>.</p> <p><b>Change the password of user mode:</b></p> <p>Step 1. Choose the user from the drop-down list.</p> <p>Step 2. Input original password, default setting is null.</p>	

	<p>Note: In admin mode, you can change the user password directly without the password of user mode.</p> <p>Step 3. Input a new password twice time in <b>New Password</b> and <b>Confirm Password</b>.</p>
--	---

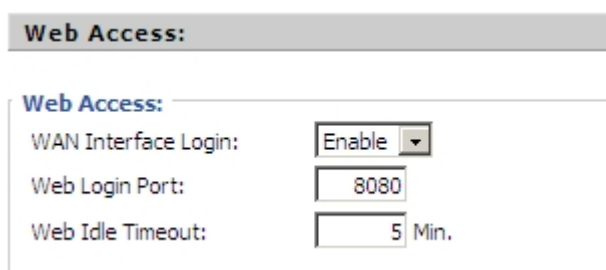
### 7.7.1.3 Web Access

Webpage	Field Name	Description
	WAN Interface Login	If or not enable user login WEB via Internet port. If enable, user can access Web to administration.
	Web Login Port	Set the port which used to login WEB via Internet port and PC port, Default is 8080, that is why URL should have 8080.
	Web Idle Timeout	Set the web idle timeout time. The web page can be logged out after <b>Web Idle Timeout</b> without any operation.

### 7.7.1.4 System Log Setting

Webpage	Field Name	Description
 <p style="text-align: center;">Picture 1</p>	SysLog Server	Set the SysLog Server IP address or domain name for IP542N.
	Log Level	Choose log level from None/Error/Warn/INFO/Debug. The priority changes from left to right, left is the lowest, right is the highest; the higher priority, the more information in syslog.
 <p style="text-align: center;">Picture 2</p>	<p>IP542N support local and remote Syslog.</p> <p><b>In local:</b></p> <p>Step 1. Set <b>syslog server</b> null and choose one kind of <b>Log Level</b>, like Picture 1.</p> <p>Step 2. Press <b>Saving Settings</b> button to save and press <b>Reboot</b> button to active</p>	

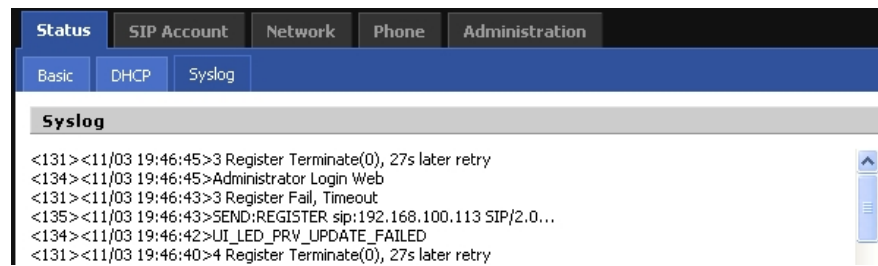

Picture 3

changes.

Step 3. User can view syslog in **Status/Syslog** webpage.

**In remote:**

Step 1. Fill in **syslog server** IP address or domain name

Step 2. Choose one kind of **Log Level**, like Picture 2.

Step 3. Press **Saving Settings** button to save and press **Reboot** button to active changes.

Step 4. User can view syslog in syslog server, and you can also view the syslog in **Status/Syslog** webpage.

### 7.7.1.5 Factory Defaults

Webpage	Field Name	Description
<p>The screenshot shows a 'Factory Defaults' section with a 'Reset to Factory Default:' label and a 'Factory Default' button. Below this are three buttons: 'Save Settings', 'Cancel Changes', and 'Reboot'.</p>		Press <b>Factory Default</b> button to set IP542N default.

### 7.7.2 Firmware Upgrade

Webpage	Description

Steps:

Step 1. Choose a upgrade file type from Upgrade Software, Upgrade Ring Voice, Upgrade Dial Plan and Upgrade Config File

Step 2. Press  to browser the upgrade file.

Step 3. Press  to start upgrading, LCD will display the notice when upgrading.

Step 4. Login web and then check the firmware whether well upgraded by viewing the firmware version in Status/Basic webpage.

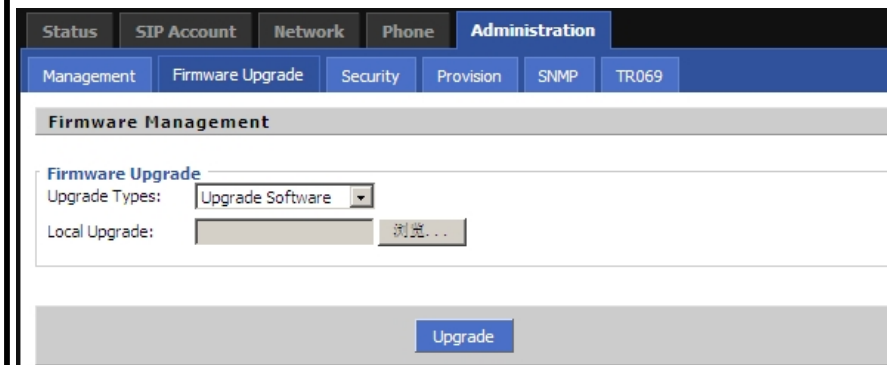

### 7.7.3 Security

Webpage	Field Name	Description
<p>Picture 1</p>	TR069 CA Certificate	The CA certificate file of TR069
	TR069 Client Certificate	The Client Certificate file of TR069
	TR069 Private Key	The Private Key file of TR069
	Provision CA Certificate	The CA certificate file of provision
	Provision Client Certificate	The Client Certificate file of provision
	Provision Private Key	The Private Key file of provision
	<p>User can upload cert files for TR069 and Provision as follows:</p> <p>Step 1. Choose one File Type from <input type="button" value="TR069 Private ke"/>, like picture 1.</p> <p>Step 2. Press <input type="button" value="browser"/> to browser file.</p> <p>Step 3. Press <input type="button" value="Update"/> to start upgrading.</p>	

Picture 2 is the webpage which all files have well uploaded.

## 7.7.4 Provision

- 1) Provisioning allow IP542N auto-upgrading or auto-configuring
- 2) IP542N supports 3 ways to provision: TFTP, HTTP and HTTPS.
  - ◆ Before testing or using TFTP, user should have tftp server and upgrading file and configuring file.
  - ◆ Before testing or using HTTP, user should have http server and upgrading file and configuring file.
  - ◆ Before testing or using HTTPS, user should have https server and upgrading file and configuring file and CA Certificate file(should same as https server's) and Client Certificate file and Private key file
- 3) User can uploading CA Certificate file and Client Certificate file and Private Key file in Equipment Manage/Cert Manage page.
- 4) Details please refer to document Provision\_User Manual\_en\_v1.1.doc

Webpage	Field Name	Description
	Provision Enabled	If or not enable provision

<b>Configuration Profile</b> Provision Enable <input type="text" value="yes"/> Resync On Reset <input type="text" value="yes"/> Resync Random Delay <input type="text" value="40"/> Resync Periodic <input type="text" value="3600"/> Resync Error Retry Delay <input type="text" value="3600"/> Forced Resync Delay <input type="text" value="14400"/> Resync After Upgrade Attempt <input type="text" value="yes"/> Profile Rule <input type="text"/> Private Key Password: <input type="text" value="whatever"/>  Phone Num1 for Config <input type="text"/> Phone Num2 for Config <input type="text"/>		Resync On Reset	If or not enable resync after IP542N restart
		Resync Random Delay	Set the maximum delay for request the synchronization file
		Resync Periodic	Set the periodic time for resync, default is 3600s
		Resync Error Retry Delay	If the last resync was failure, IP542N will retry resync after the "Resync Error Retry Delay" time, default is 3600s
		Forced Resync Delay	If it's time to resync, but IP542N is busying now, in this case, IP542N will wait for a period time, the longest is "Forced Resync Delay" , default is 14400s, when the time over, IP542N will forced to resync
		Resync After Upgrade Attempt	If or not enable firmware upgrade after resync, "yes" is enable
<b>Firmware Upgrade</b> Upgrade Enable <input type="text" value="yes"/> Upgrade Error Retry Delay <input type="text" value="3600"/> Downgrade Rev Limit <input type="text" value="0"/> Upgrade Rule <input type="text"/>		Profile Rule	URL of profile provision file
		Phone Num1 for Config	The first phone number which used to reboot IP542N in remote.
		Phone Num2 for Config	The second phone number which used to reboot IP542N in remote.
		Auto-upgrade Enabled	If or not enable firmware upgrade.
		Auto-upgrade Error Retry Delay	Set the time to retry upgrade, effective when the last upgrade was failure
		Upgrade Rule	URL of upgrade file

### 7.7.5 SNMP

Webpage	Field Name	Description
	SNMP Enable	If or not enable SNMP
	Get Community	String, as an express password between management process and the agent process

	Set Community           SNMP Manager IP 1-4	String, as an express password between management process and the agent process           The IP address of SNMP Manager
--	--	---

## 7.7.6 TR069

Webpage	Field Name	Description
	TR069 Enable	If or not enable TR069
	CWMP	If or not enable TR069
	ACS URL	The URL of TR069 server
	User Name	The IP542N's user name for connecting to TR069 server
	Password	The IP542N's password for connecting to TR069 server
	Periodic Inform Enable	If or not enable periodic information
	Periodic Inform Interval	The interval to send information to TR069 server
	User Name	The TR069 server's user name for connecting to IP542N
	Password	The TR069 server's password for connecting to IP542N
	SSL Key	Fill in SSL key.

# 8 Troubleshooting

This section provides solutions to problems that can occur during the installation and operation of the IP phone. Read the following descriptions if you are having problems.

## 8.1 No Operation after Power On

**Solution:**

Check if the power adapter is properly connected.

If applicable, check if the PoE (Power over Ethernet) switch behind the IP phone is set correctly.

## 8.2 No Dial Tone

**Solution:**

Check if the handset cord is properly connected.

## 8.3 Can not Make a Call

**Solution:**

Check the status of your SIP registration status or contact your administrator, supplier, or ITSP for more information or assistance.

## 8.4 Can not Receive Any Phone Call

**Solution:**

Check the status of your SIP registration status, or contact your administrator, supplier, or ITSP for more information or assistance.

## 8.5 No Voice during an Active Call

**Solution:**

Check if the servers support the current audio codec type, or contact your administrator, supplier, or ITSP for more information or

assistance.

Audio Configuration			
Audio Codec Type 1:	G.711U	Audio Codec Type 2:	G.711A
Audio Codec Type 3:	G.729	Audio Codec Type 4:	G.722
Audio Codec Type 5:	G.723	G.723 Coding Speed:	5.3k bps
Packet Cycle(ms):	20ms		
Silence Supp Enable:	Disable	Echo Cancel:	Enable

## 8.6 Can not connect to the configuration Website

### Solution:

Check if the Ethernet cable is properly connected.

Check if the URL is right wrote, the format of URL is: **http:// the Internet port IP address: 8080, 8080** must be added.

Check if your firewall/NAT settings are correct.

Check if the version of IE is IE8, or use other browser such as Firefox or Mozilla, or contact your administrator, supplier, or ITSP for more information or assistance.

## 8.7 Forget the Password

Default password of website and menu is null.

If user changed the password and then forgot, you can not access to the configuration website or the menu items which need password.

### Solution:

Factory default: press **Menu** button and choose **16Factory Default**, then a notice will appear, choose OK by using the corresponding softkey button.

If you choose factory default, you will return the phone to the original factory settings and will erase ALL current settings, including the directory and call logs.

# 9 Contact ways

If you have any questions, please contact us. The following chart describes the ways briefly.

## Beijing Flying Voice Technology Limited

Beijing	Shenzhen
Add: Room415, ChuangXin Building A#, NO.12 HongDa North Rd, BDA, Beijing, China	Add: Room7007, Tiansha Building, MajiaLong, Industrial area, NanShan district, Shenzhen, China
ZIP code: 100176	ZIP code:518052
Tel: +86-10-67886296	Tel: +86-755-26099365
Fax: +86-10-67883237	Fax: +86-755-26099347

Support: [support@flyingvoice.com](mailto:support@flyingvoice.com)

Sales: [sales@flyingvoice.com](mailto:sales@flyingvoice.com)