



DPL Surge Arrester

Fig. 1 Mounting / Montage

- DE Einbauanleitung
- GB Installation instructions
- IT Istruzioni di montaggio
- FR Instructions de montage
- NL Montagehandleiding
- ES Instrucciones de montaje
- PT Instruções de montagem
- DK Monteringsvejledning
- SE Monteringsanvisning
- FI Asennusohje
- GR Οδηγίες συναρμολόγησης
- PL Instrukcja montażu
- CZ Montážní návod
- TR Kurulum Talimatları
- RU Инструкция по монтажу
- CN 安装说明
- HU Szerelési útmutató
- JP 設置説明書

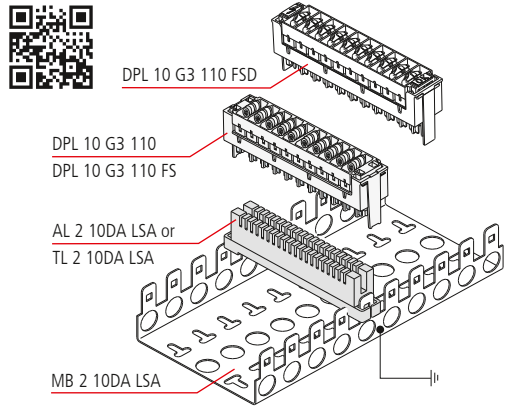

Fig. 2

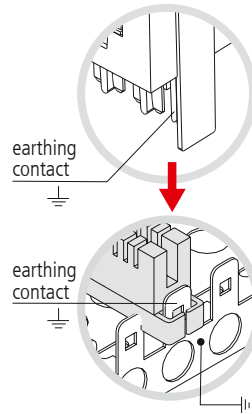

Fig. 3 Grounding / Erdung

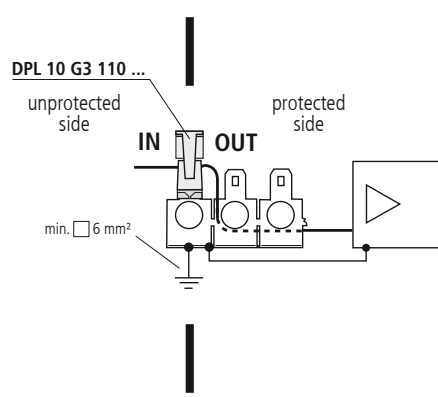

Fig. 4 Fail-safe

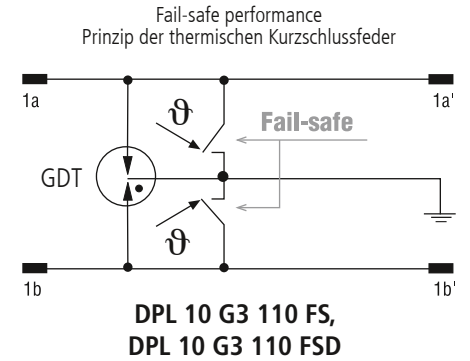
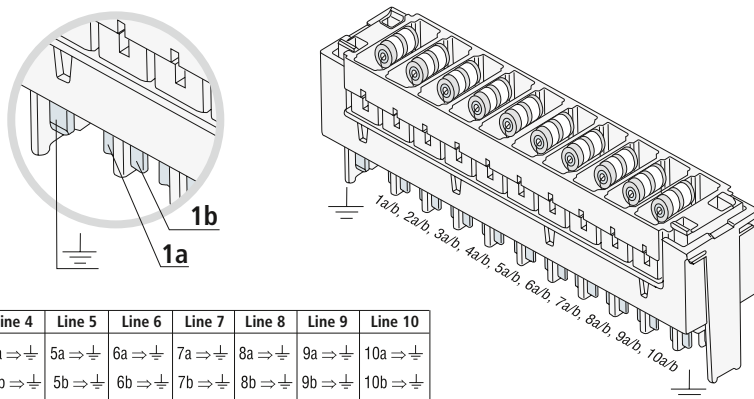

Fig. 5 Test gas discharge tube / Test Gasableiter

DPL 10 G3 110,  
DPL 10 G3 110 FS



Test	Line 1	Line 2	Line 3	Line 4	Line 5	Line 6	Line 7	Line 8	Line 9	Line 10
PIN	1a → ⊥	2a → ⊥	3a → ⊥	4a → ⊥	5a → ⊥	6a → ⊥	7a → ⊥	8a → ⊥	9a → ⊥	10a → ⊥
PIN	1b → ⊥	2b → ⊥	3b → ⊥	4b → ⊥	5b → ⊥	6b → ⊥	7b → ⊥	8b → ⊥	9b → ⊥	10b → ⊥

Fig. 6 Test, Measuring / Test, Messung

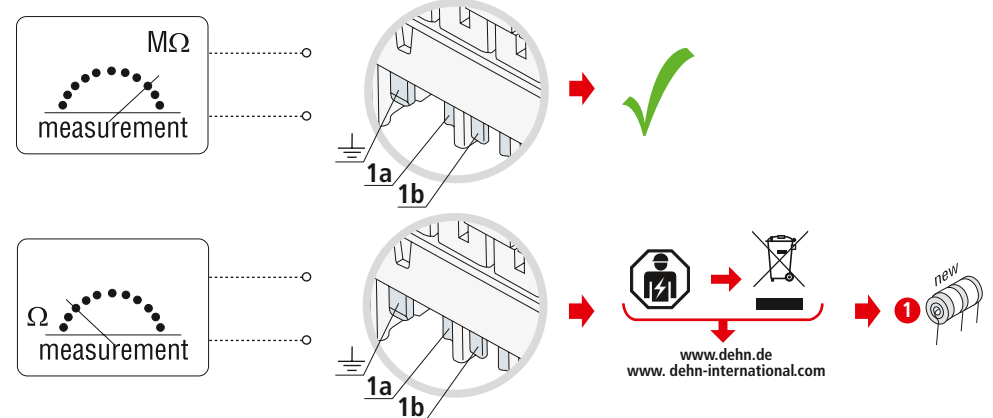

Fig. 7 Colour code / Farbcode

DPL 10 G3 110 FSD

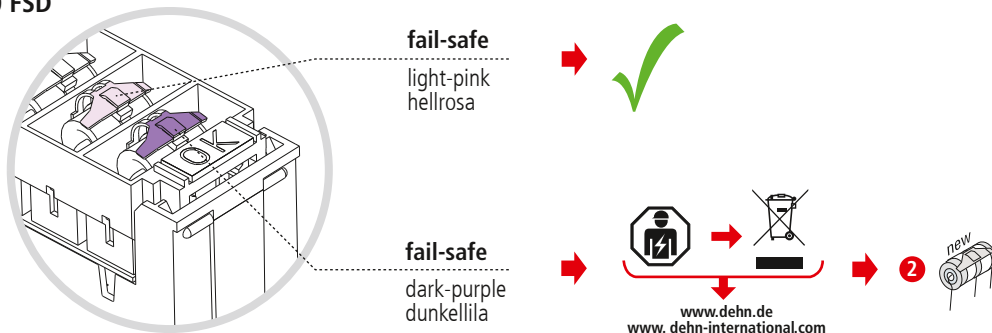

Fig. 8 Exchange / Austausch

- 1 **Spare Part / Ersatzteil**  
Gas discharge tube **without fail safe** (230 V)  
Gasableiter **ohne fail safe** (230 V)  
907 208
- 2 **Spare Part / Ersatzteil**  
Gas discharge tube **with fail safe** and colour change (230 V)  
Gasableiter **mit fail safe** und Farbumschlag (230 V)  
907 217

