

OptiView® XG NETWORK ANALYSIS TABLET

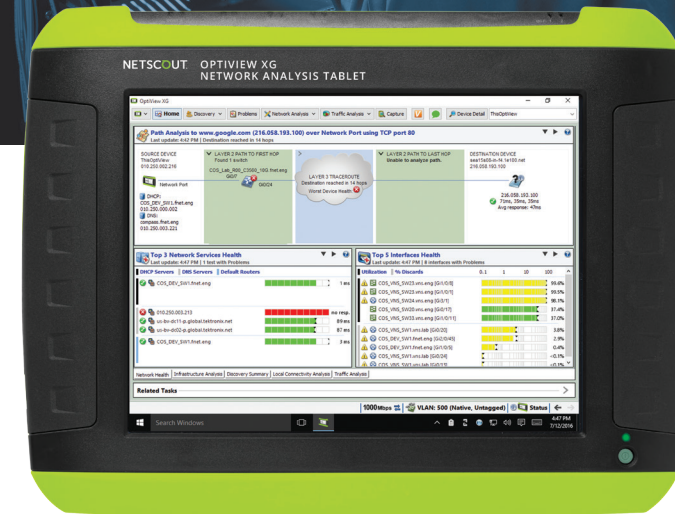
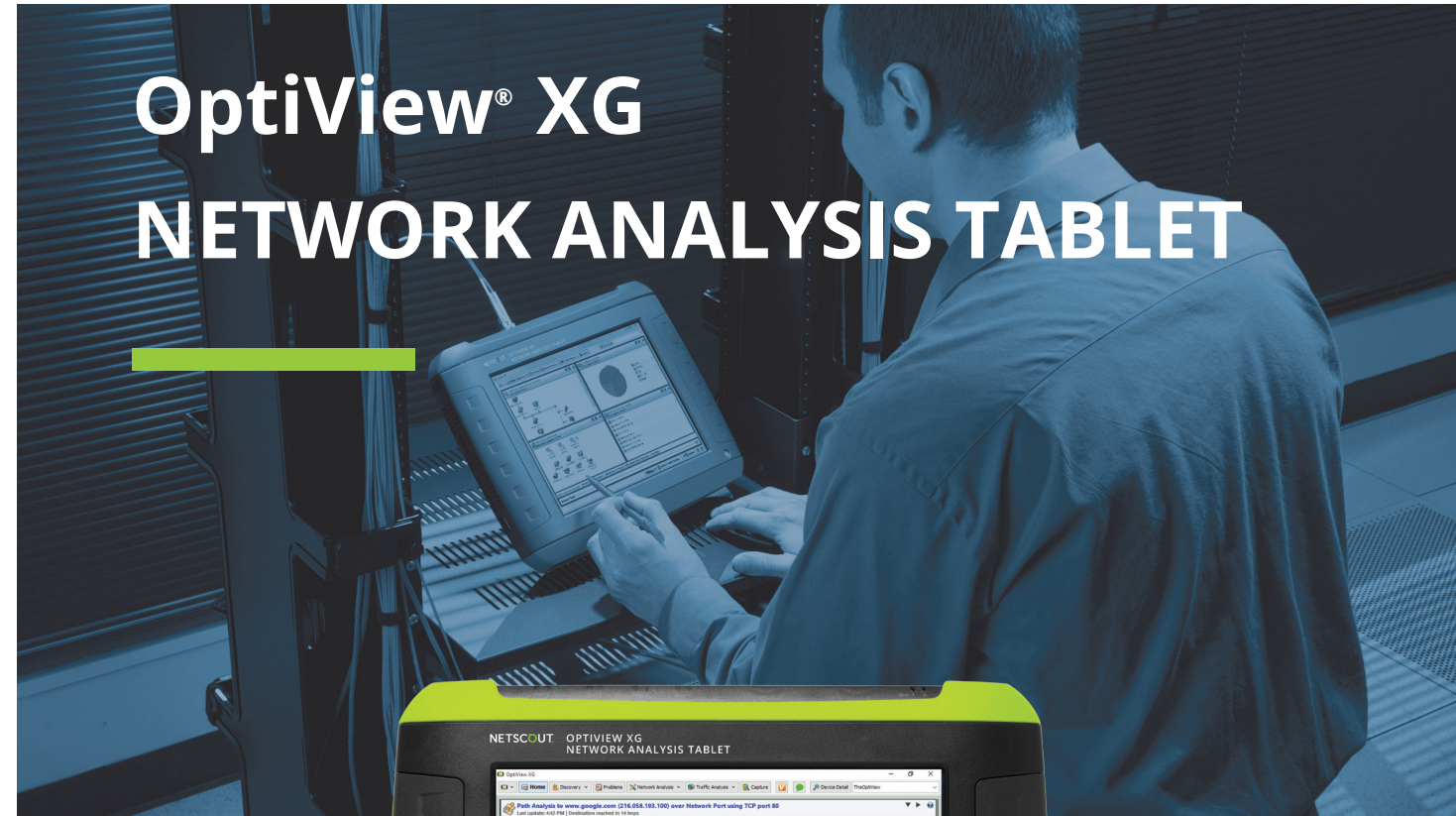

NETSCOUT®

Americas East

310 Littleton Road
Westford, MA 01886-4105
Phone: 978-614-4000
Toll Free: 800-357-7666

Americas West

178 E. Tasman Drive
San Jose, CA 95134
Phone: 408-571-5000

Asia Pacific

17F/B
No. 167 Tun Hwa N. Road
Taipei 105, Taiwan
Phone: +886 2 2717 1999

Europe

One Canada Square
29th floor, Canary Wharf
London E14 5DY
United Kingdom
Phone: +44 207 712 1672

NETSCOUT offers sales, support, and services in over 32 countries.

© 2016 NETSCOUT SYSTEMS, INC. All rights reserved. NETSCOUT, nGenius, InfiniStream, Sniffer, nGeniusONE, ASI, Adaptive Service Intelligence and the NETSCOUT logo are registered or pending trademarks of NETSCOUT SYSTEMS, INC. and/or its affiliates in the United States and/or other countries ("NETSCOUT"). All other brands and product names and registered and unregistered trademarks are the sole property of their respective owners. Use of this product is subject to the NETSCOUT SYSTEMS, INC. ("NETSCOUT") End User License Agreement that accompanies the product at the time of shipment or, if applicable, the legal agreement executed by and between NETSCOUT and the authorized end user of this product ("Agreement"). NETSCOUT reserves the right, at its sole discretion, to make changes at any time in its technical information, specifications, service, and support programs.

For more information, please visit www.enterprise.netscout.com or contact NETSCOUT at 800-309-4804 or +1 978-614-4000

PN: 790-000001

EGSG_7001157-1600

GETTING STARTED GUIDE



NETSCOUT®

OPTIVIEW® XG

NETWORK ANALYSIS TABLET

Getting Started Guide



PN 790-000001

Released August 2016, Rev. 5

© 2016 NETSCOUT SYSTEMS, Inc. All rights reserved. Printed in USA.
All product names are trademarks of their respective companies.

LEGAL NOTIFICATION

Use of this product is subject to the End User License Agreement available at <http://www.netscout.com/legal/terms-and-conditions/> or which accompanies the product at the time of shipment or, if applicable, the legal agreement executed by and between NETSCOUT SYSTEMS, INC., and the purchaser of this product ("Agreement").

Government Use and Notice of Restricted Rights: In U.S. government ("Government") contracts or subcontracts, Customer will provide that the Products and Documentation, including any technical data (collectively "Materials"), sold or delivered pursuant to this Agreement for Government use are commercial as defined in Federal Acquisition Regulation ("FAR") 2.101 and any supplement and further are provided with RESTRICTED RIGHTS. All Materials were fully developed at private expense. Use, duplication, release, modification, transfer, or disclosure ("Use") of the Materials is restricted by the terms of this Agreement and further restricted in accordance with FAR 52.227-14 for civilian Government agency purposes and 252.227-7015 of the Defense Federal Acquisition Regulations Supplement ("DFARS") for military Government agency purposes, or the similar acquisition regulations of other applicable Government organizations, as applicable and amended. The Use of Materials is restricted by the terms of this Agreement, and, in accordance with DFARS Section 227.7202 and FAR Section 12.212, is further restricted in accordance with the terms of NETSCOUT's commercial End User License Agreement. All other Use is prohibited, except as described herein.

This Product may contain third-party technology. NETSCOUT may license such third-party technology and documentation ("Third-Party Materials") for use with the Product only. In the event the Product contains Third-Party Materials, or in the event you have the option to use the Product in conjunction with Third-Party Materials (as identified by NETSCOUT in the applicable Documentation), then such third-party materials are provided or accessible subject to the applicable third-party terms and conditions contained in the "Read Me" or "About" file located on the Application CD for this Product. To the extent the Product includes Third-Party Materials licensed to NETSCOUT by third parties, those third parties are third-party beneficiaries of, and may enforce, the applicable provisions of such third-party terms and conditions.

Open-Source Software Acknowledgment: This product may incorporate open-source components that are governed by the GNU General Public License ("GPL") or licenses that are compatible with the GPL license ("GPL Compatible License"). In accordance with the terms of the GNU GPL, NETSCOUT will make available a complete, machine-readable copy of the source code components of this product covered by the GPL or applicable GPL Compatible License, if any, upon receipt of a written request. Please identify the product and send a request to:

NetScout Systems, Inc.
GNU GPL Source Code Request
310 Littleton Road
Westford, MA 01886
Attn: Legal Department

NETSCOUT SYSTEMS, INC. reserves the right, at its sole discretion, to make changes at any time in its technical information, specifications, service, and support programs.

Rev. 02/04/2016

Table of Contents

Title	Page
Safety Information	1
Symbols	2
Introduction	3
10/100/1000Mbps/10Gbps Wired	3
Package Contents	6
Optional Accessories	8
Shipping Damage	9
Registering the OptiView XG	10
Registering the NETSCOUT AirMagnet Products	10
AirMagnet Gold Support Registration	10
Contacting NETSCOUT	11
Context-Sensitive Help System	12
AirMagnet Product Documentation	12
Operating your OptiView XG	13
Connectors, Controls, and Indicators	13
Stylus	17
Extending the Stand	17
Power Modes	18
Powering On	18
Sleep Mode	19
Powering-Off	20
Using the Touchscreen, Stylus, Keyboard, and Mouse	21
Screen Use and Care	21
Windows Touchscreen Settings	21
Virtual Keyboard	22
Virtual Keyboard in Windows 7	22
Virtual Keyboard in Windows 10	23
Connecting the OptiView XG to a Network	24
Establishing a Wired or Fiber Connection	24
Network Ports	24
Link Speed and Utilization Indicators	25
Installing/Removing the SFP or SFP+ Fiber Adapter (Transceiver)	25
Establishing a Wireless Connection	26
OptiView XG Wireless Capabilities	26
Enabling the Wi-Fi Adapters	27
Wi-Fi Adapters Not Enabled	27
Wi-Fi Adapters Enabled	28
Connecting to Wireless Networks in Windows	29
Managing Wi-Fi on an OptiView XG Tablet with Windows 7	31
Managing Wi-Fi on an OptiView XG Tablet with Windows 10	33
Viewing Wireless Settings with Windows 10	33
Managing Wireless Network Profiles with Windows 10	34

Wi-Fi Indicators	35
Configuring the OptiView XG for Use with Your Network	36
Operating the OptiView XG on Battery Power	37
Battery Operation	37
Charging the Batteries	37
Power/Charge Indicator	37
Displaying the Battery Charge Status Window	38
Battery Charge Indicators (on batteries)	38
Replacing/Hot Swapping the Batteries	39
Battery Life in Sleep or Shut down Modes	39
Battery Care	40
Extending Battery Operating Time	40
To Switch Off Power to Network Ports A, B, C, and D	40
Connecting External Devices	42
Keyboard, Mouse, Flash Drive, Printer, and Other USB Devices	42
External eSATA Hard Drive	42
External Antenna	42
Power Connector	43
VGA Port for External Monitor	43
Controlling the OptiView XG from a Remote Computer	44
Remote PC Requirements	44
Installing the Remote User Interface	44
Install from Flash Drive	44
Install from the OptiView XG's Home Page	44
Using the Remote User Interface to Access the OptiView XG User Interface	44
Launch OptiView Browser	44
Initiate a Remote Session	45
Encrypting Data Over the Remote User Interface	45
To Set Up Remote User Interface Encryption	46
Remote Connection Termination	46
Security	47
Physical Security: Kensington Lock	47
Controlling Access to the OptiView XG	47
Locking Windows	47
OptiView XG User Accounts	47
To Set Up User Accounts	48
Removing and Replacing the Hard Drive	50
Removing the Hard Drive	50
Replacing the Hard Drive	50
Changing the Computer Name	51
Cleaning	51
Troubleshooting	52
Windows Restore Options	53
Windows System Restore	53
Restoring Windows Configuration from a Previous Windows 7 Restore Point	53
Windows System Recovery	53
Windows 7 Back Up and Recovery Procedure	54
Back Up Your Files	54
Recover Windows System Files	54
Post-Recovery File Clean-Up	55

Windows 10 Back Up and Recovery Procedure 55

 Back Up Your Files 55

 Recover Windows System Files 56

Specifications 57

 Physical Specifications 57

 Environmental Specifications 57

 Electrical Specifications 58

 Cables 59

 Wireless Antennas 59

 Wireless Adapters 1 and 2 60

 Supported Network Standards 61

 Compliance Statements 61

 Federal Communication Commission and Industry Canada Interference Statement 61

 OptiView XG Identification Numbers 62

 Exposure to RF Energy 63

 Europe-EU Declaration of Conformity 63

Contacting NETSCOUT 66

Safety Information

Warning

- With an optional SFP or SFP+ fiber adapter installed, the Product contains a Class 1 laser.
- Do not look directly into optical connectors while powered on. Some optical equipment emits invisible radiation that can cause permanent damage to your eyes.
- Do not look directly into the laser with optical tools (for example, binoculars, telescopes, microscopes). Optical tools can focus the laser and be dangerous to the eye.
- Use the Product only as specified or hazardous laser radiation exposure can occur.
- Carefully read all instructions and safety information before using the Product.
- Do not use the Product if it operates incorrectly.
- Use the Product only as specified, or the protection supplied by the Product can be compromised.
- Do not operate the Product around explosive gas, vapor or in damp or wet environments.
- Do not expose batteries to fire.
- Do not short circuit or disassemble batteries.
- Do not expose batteries to temperatures above 70°C.
- Use charging procedures specified in manual.
- Use only Netscout supplied charger and battery packs in the instrument.
- Batteries must be recycled or disposed of properly.

Caution

This equipment generates, uses, and can radiate radio frequency energy, and, if not installed and used in accordance with its intended use, may cause interference to radio communications. This device has been tested and found to comply with the limits for a Class A digital device pursuant to Part 15 of the FCC rules, which are designed to provide reasonable protection against such interference when operated in a commercial environment. Operation of the equipment in a residential area is likely to cause interference, in which case the user, at his own expense, will be required to take appropriate measures to correct the interference.













Caution

- Do not connect the Product to a telephone line or an ISDN line.
- Use the correct cables and connectors when connecting the Product to a network.
- Do not block or restrict the Product's air intake or exhaust ports.

Symbols

The following symbols appear on the product or in the manual.

Table 1. Symbols

	Not for connection to public telephone systems.
	Please read manual for safety.
	Shock hazard.
	Class 1 laser product. Do not look into laser. Complies with EN/IEC 60825-1:2007
	Do not put products that contain circuit boards into waste containers. Refer to local regulations for disposal procedures.
	Recycle lithium-ion batteries.
	Complies with European Union directives.
	Complies with CAN/CSA-C22.2 no. 61010-1-04 Canadian standards, and UL61010-1:2004 (US standards).
	Meets Australia EMC requirements.
	Conforms to FCC rules, parts 15.107, 15.109.
	Industry Canada, complies with Canadian safety standards.
	Batteries: Useful life is approximately 5 years. Year of battery manufacture is shown beneath symbol.
	TUV Rheinland safety and EMC compliant.

Introduction

The OptiView® XG Network Analysis Tablet comes in four configurations:

- 10/100/1000Mbps wired only
- 10/100/1000Mbps wired and 802.11 wireless
- The above with 10Gbps wired
- Wireless only

The bulk of this manual applies to the 10/100/1000Mbps/10Gbps wired and 802.11 wireless configuration. Some sections are specific to wireless only and are indicated as “wireless only.” The wireless only configuration enables the AirMagnet WiFi Analyzer PRO and optional AirMagnet Spectrum XT and/or AirMagnet Survey PRO/Planner products to run on the OptiView XG Network Analysis Tablet in stand alone mode. These products are described in their own User Guides.

If this tablet is configured for wireless only, the OptiView XG 10/100/1000Mbps/10Gbps wired product is disabled, but can be enabled if purchased at some later date. If purchased, key codes will be provided to turn on this part of the tablet. Refer to Appendix A for procedures on enabling the OptiView XG 10/100/1000Mbps/10Gbps wired product.

10/100/1000Mbps/10Gbps Wired

The tablet enables users to monitor and analyze key assets remotely from the desk and troubleshoot locally "on-the-wire." It's an all-in-one portable network analysis tool designed to help network professionals save time resolving performance problems that are impacting the end-user experience. The flexible user interface allows for custom presentation of information and test results to meet specific needs. The OptiView XG also provides accurate reporting and documentation of the network.

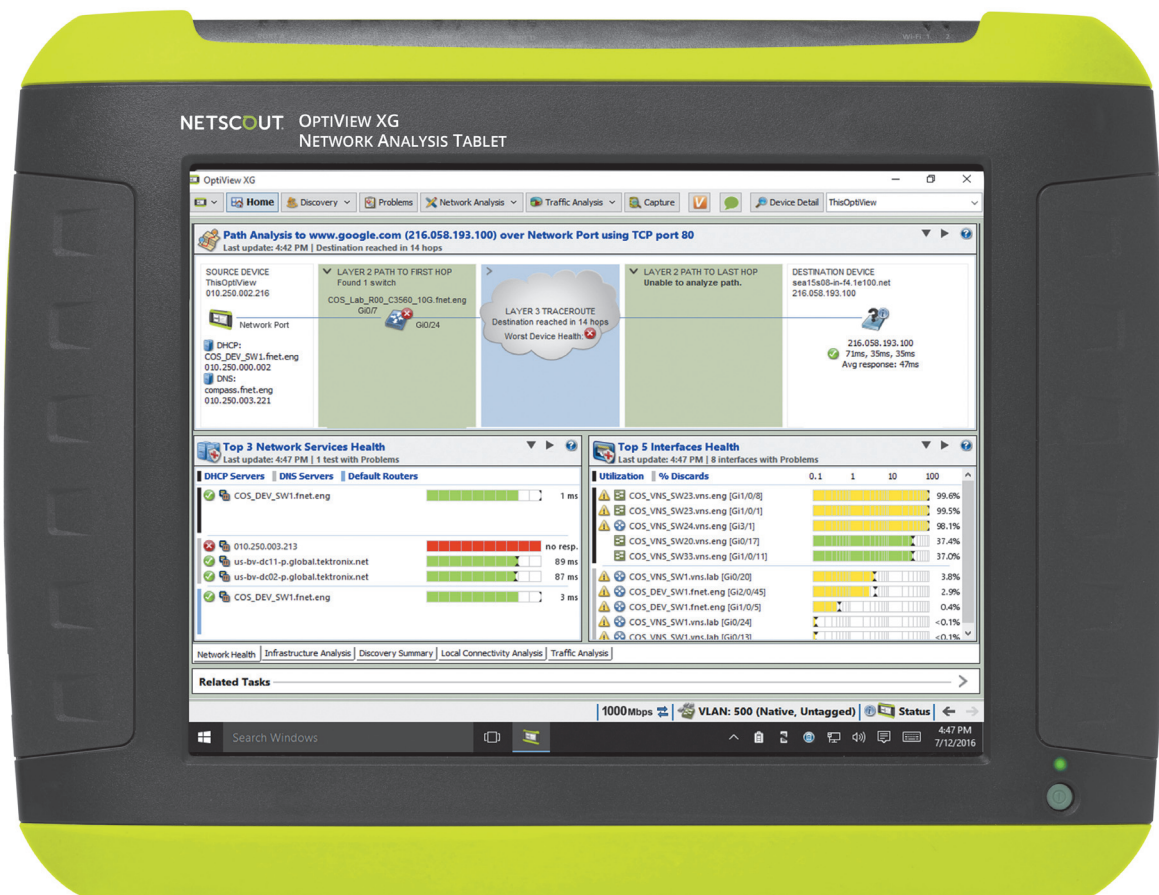

Figure 1. OptiView XG Network Analysis Tablet with 10/100/100Mbps/10Gbps Wired Enabled

OptiView XG Network Analysis Tablet

Getting Started Guide

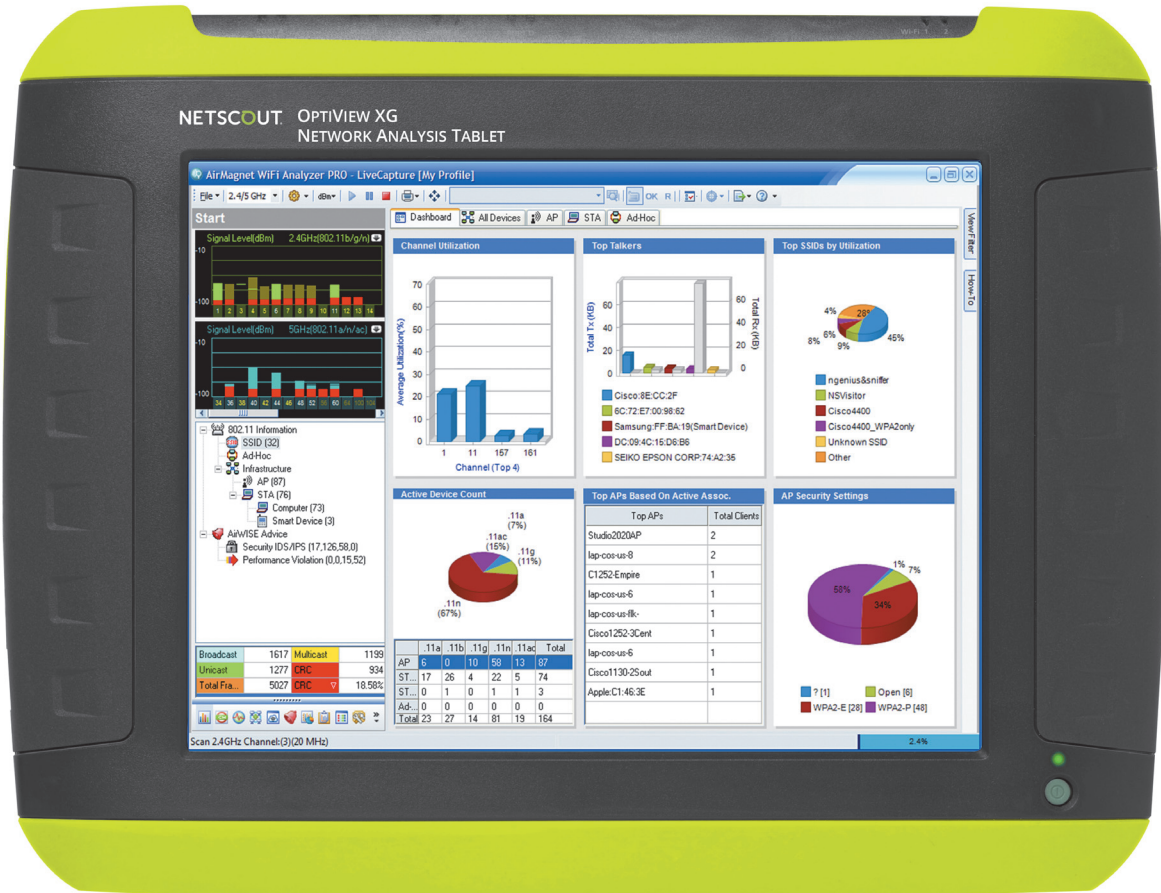

Figure 2. OptiView XG Network Analysis Tablet with Wireless Only Enabled

Package Contents

Verify that the following items are supplied with your OptiView XG Network Analysis Tablet in the 10/100/1000Mbps/10Gbps wired only configuration.

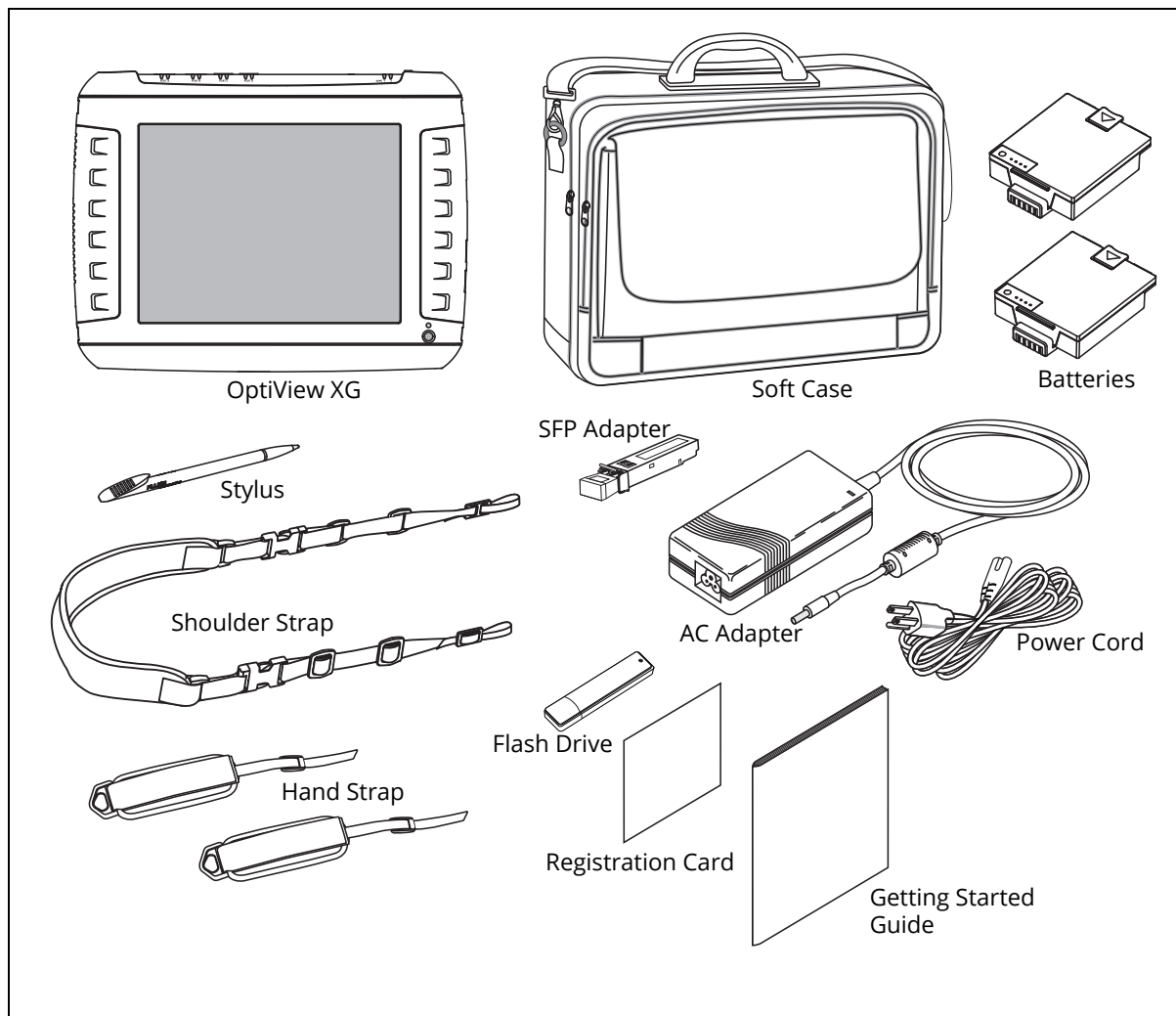

Figure 3. Supplied Items

NOTE

If the wireless configuration is purchased, the AirMagnet user guides are provided. For the wireless only configuration, the SFP adapter is not provided. For the 10-Gbps wired configuration, an additional 10-Gbps SFP adapter is provided.

Table 2. Supplied Items for Wired Only Configuration

Item	Description	Model Number
OptiView XG	Network Analysis Tablet.	—
1000BASE-SX SFP	1000BASE-SX SFP optical transceiver module (adapter), 850 nm, 50 and 62.5 micron multi-mode.	OPV-SFP-SX
Stylus	Stylus for use on OptiView XG touchscreen.	OPVXG-STYLUS
Batteries	Set of two lithium-ion batteries with built-in charge indicators. Provides approximately two hours of run time.	OPVXG-BATTERY
Hand and Shoulder Straps	Attach to the OptiView XG for easy carrying.	OPVXG-STRAPS
Soft Case	Protective soft case.	OPVXG-CCASE
AC Adapter	Input: 90-264 VAC, 47-63 Hz, 2.0 A max Output: 19 VDC, 4.74 A, 90 W. ⚠ Caution: For safe operation, use only the supplied AC adapter.	OPVXG-PS
AC power cord	Country-specific AC power cord (line cord).	—
Getting Started Guide	This document.	—
Flash Drive	Includes Remote User Interface software, Help System, and Getting Started Guide in multiple languages, PDF format.	—
Registration Card	NETSCOUT can best serve you when you register online at www.enterprise.netscout.com . If you cannot register online, please fill out and return the supplied registration card.	—

Optional Accessories

The following accessories were available when this manual was printed. For an updated list see www.enterprise.netscout.com.

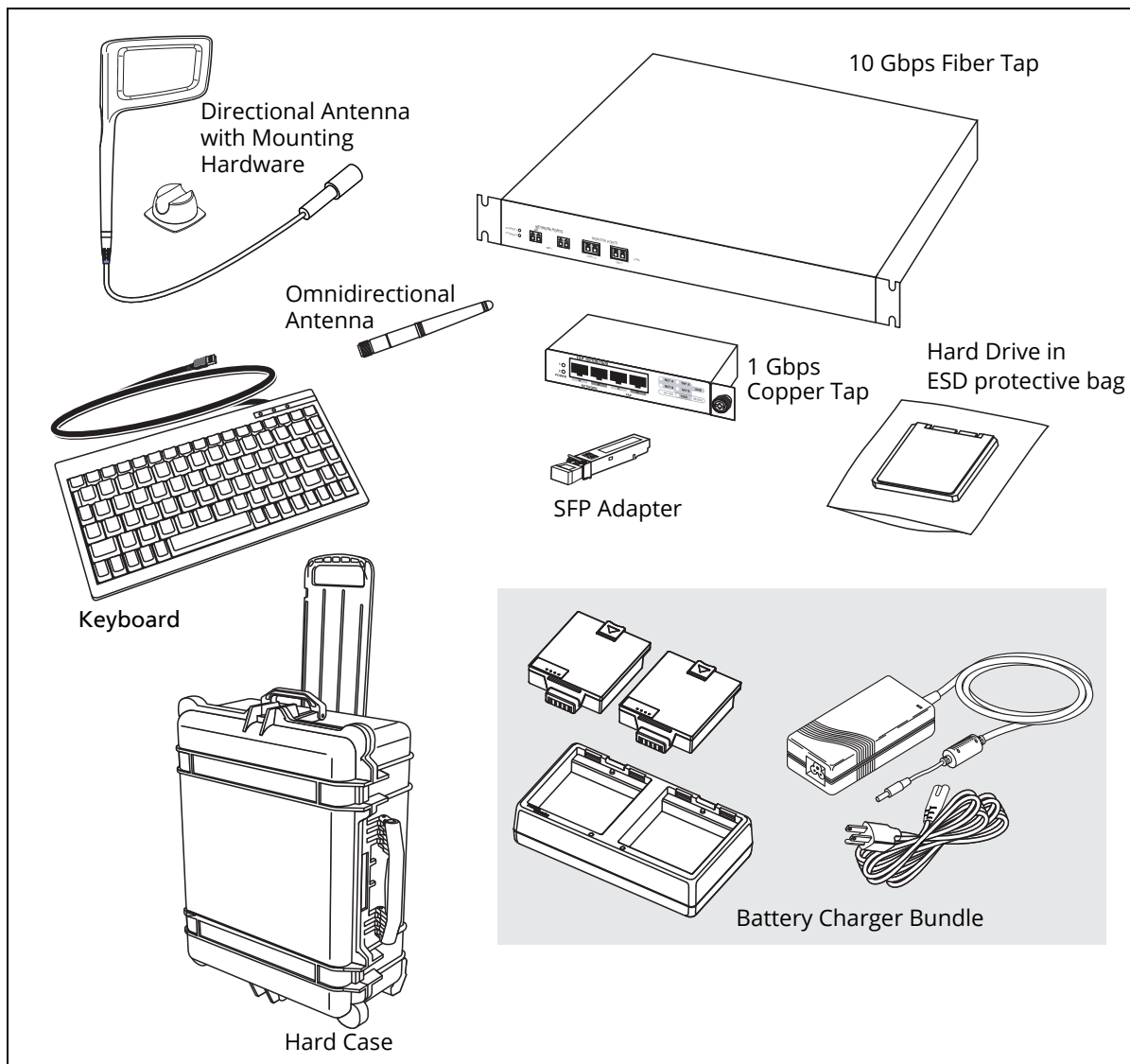

Figure 4. Optional Accessories

Table 3. Optional Accessories

Item	Description	Model Number
Directional Antenna	Directional Antenna for use with AirMagnet WiFi Analyzer PRO and Spectrum XT applications.	OPV-DIRECT-ANT
Omnidirectional Antenna	Omnidirectional antenna for use with AirMagnet applications.	OPV-OMNI-ANT
Keyboard	Small-footprint USB keyboard for connection to OptiView XG.	OPVS2-KB
Hard Case	Hard-sided carrying case.	OPVXG-HCASE
Removable Hard Drive ¹	Removable hard drive, supplied in static-resistive bag.	OPVXG-RHD
Tap, Fiber	10 Gbps in-line filtering fiber tap with two XFP any-to-any ports.	FAXTAP1204SR-10G
Tap, Copper	1 Gbps in-line copper tap. Passive @ 10/100 Mbps, active @ 1000 Mbps.	TAP-10/100/1000
Battery Charger Bundle	Set of two battery packs, charging station, AC adapter, and line cord.	OPVXG-BATT-KIT
10G Fiber SFP+ SR adapter	10GBASE-SR SFP+ optical transceiver module (adapter), 850 nm multi-mode.	OPVXG-SFP-PLUS-SR
10G Fiber SFP+ LR adapter	10GBASE-LR SFP+ optical transceiver module (adapter), 1310 nm single mode.	OPVXG-SFP-PLUS-LR
10G Fiber SFP+ LRM adapter	10GBASE-LRM SFP+ optical transceiver module (adapter), 1310 nm multi-mode.	OPVXG-SFP-PLUS-LRM
1G Fiber SFP SX adapter	1000BASE-SX SFP optical transceiver module (adapter), 850nm, 50 and 62.5 micron multi-mode.	OPV-SFP-SX
1G Fiber SFP LX adapter	1000BASE-LX SFP optical transceiver module (adapter), 1300 nm, 10 micron single mode.	OPV-SFP-LX
1G Fiber SFP ZX adapter	1000BASE-ZX SFP optical transceiver module (adapter), 1550 nm, single mode.	OPV-SFP-ZX
100M Fiber SFP FX adapter	100BASE-FX SFP optical transceiver module (adapter), 1310 nm.	OPV-SFP-100FX

¹Use standard ESD protection practices when handling this item.

Shipping Damage

If shipping damage has occurred, call the carrier immediately and file a claim. Then contact NETSCOUT (see [page 11](#)) to arrange repair or replacement.

Registering the OptiView XG

To register, go to <http://www.enterprise.netscout.com/registration>. If you do not already have an account, select the **Create Account** button to proceed.

You can also register the OptiView XG by filling out the registration card and sending it to NETSCOUT.

Registration provides the following benefits:

- Notification of software updates
- Three free telephone support incidences during the first 60 days of product ownership
- Access to the online Knowledge Base
- Web-based trouble ticket support

Registering the NETSCOUT AirMagnet Products

Customers of AirMagnet products are encouraged to register their products and take advantage of the benefits of a “My AirMagnet” account.

Additionally, NETSCOUT Gold Support is our comprehensive support and maintenance program that offers expanded coverage for all AirMagnet products.

To register AirMagnet products:

1. Go to http://airmagnet.netscout.com/support/register_product/
2. Enter the product serial number in the space provided. Leave the MAC address option unchecked.
3. Select whether you currently have a My AirMagnet account.
4. Click **Next**.
5. Complete the Product Registration form (including the Serial Key information).
6. Click **Submit**.

AirMagnet Gold Support Registration

Customers with Gold Support will receive a unique support **serial number** and **serial key** for each AirMagnet product included in their Gold Support contract. The support serial number and serial key must be registered in order for Gold Support to be activated. After registering the product, this can be accomplished in the Registered Products section of your My AirMagnet account at:

http://airmagnet.netscout.com/my_airmagnet/public/registered_products

Contacting NETSCOUT

Web: www.enterprise.netscout.com

For more contact information, visit our website.

Email: customercare@netscout.com

Phone: Toll free +1-844-833-3713; International 978-320-2150

Context-Sensitive Help System

On the OptiView XG analyzer user interface, select the blue question mark to show help for the current screen.

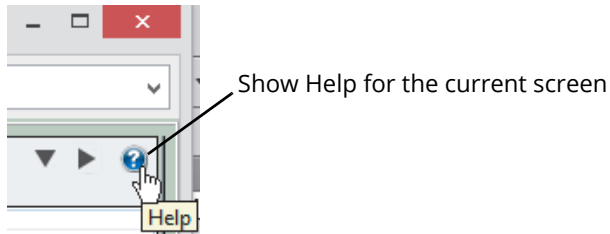

Figure 5. OptiView XG Help Button

AirMagnet Product Documentation

Each AirMagnet product includes the following documentation: ReadMe (PDF), Release Notes (PDF), User Guide (PDF), and a User Guide in online help format. To locate documentation, go to:

- the Help menu within each application
- the product folder under C:\Program Files (x86)\AirMagnet Inc

within your [AirMagnet.Netscout.com](https://www.airmagnet.net) "My AirMagnet" account under "Documents > Drivers".

Operating your OptiView XG

Connectors, Controls, and Indicators

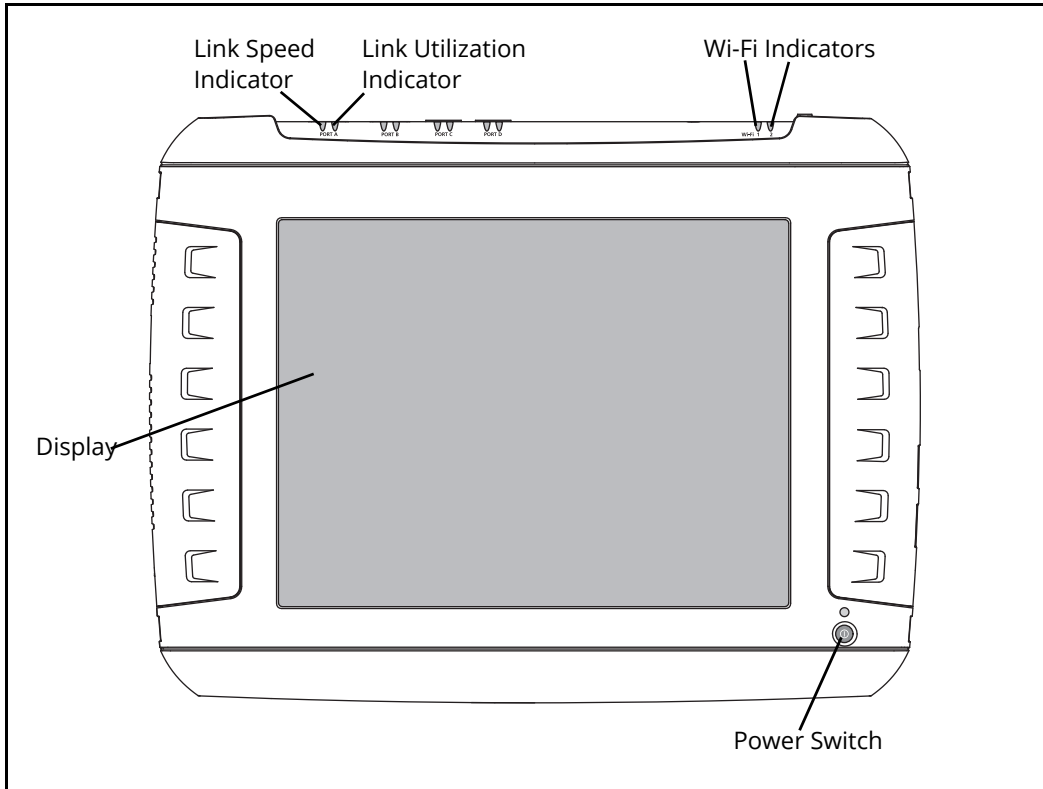

Figure 6. Front View

- Link Speed Indicator, see [page 25](#).
- Link Utilization Indicator, see [page 25](#).
- Wi-Fi Indicators, see [page 35](#).
- Power Switch, see [page 18](#).
- Multi-Touch Display, see [page 21](#).

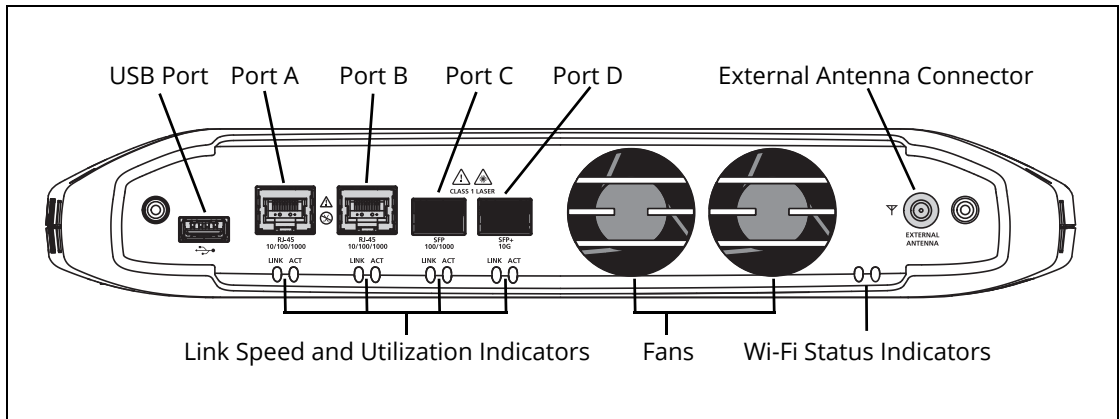

Figure 7. Top View

- USB Port, see [page 42](#).
- Network Ports A, B, C, and D; see [page 24](#).
- External Antenna Connector, see [page 42](#).
- Link Speed Indicator, see [page 25](#).
- Link Utilization Indicator, see [page 25](#).
- Wi-Fi Indicators, see [page 35](#).

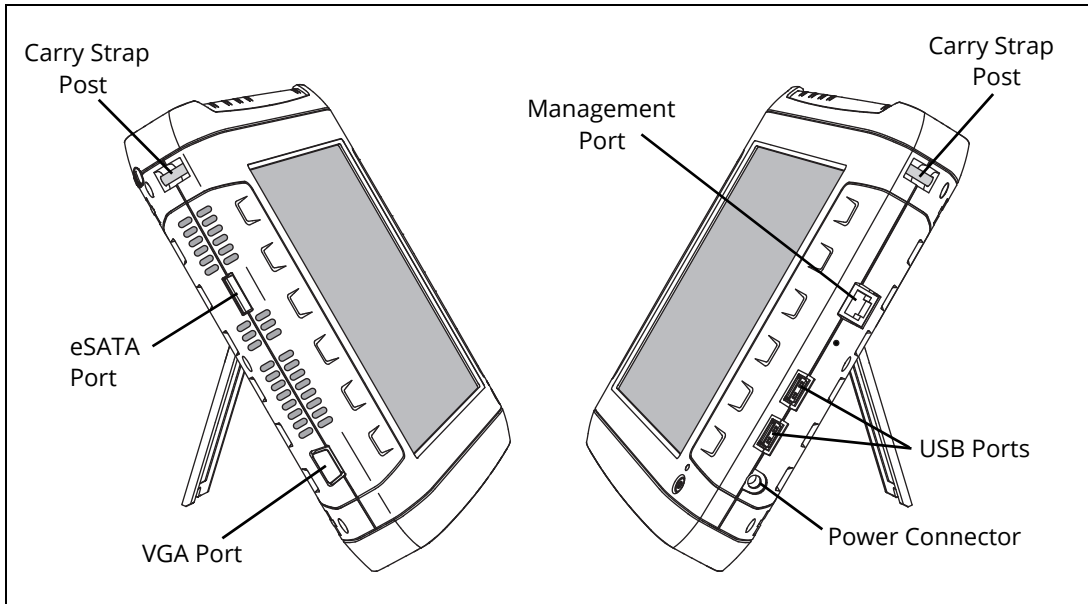

Figure 8. Left and Right Side Views

- Carry strap post, for connecting carry strap.
- eSATA connector, see [page 42](#).
- VGA Port, see [page 43](#).
- Management Port, see [page 24](#).
- USB Ports, see [page 42](#).
- Power Connector, see [page 18](#).

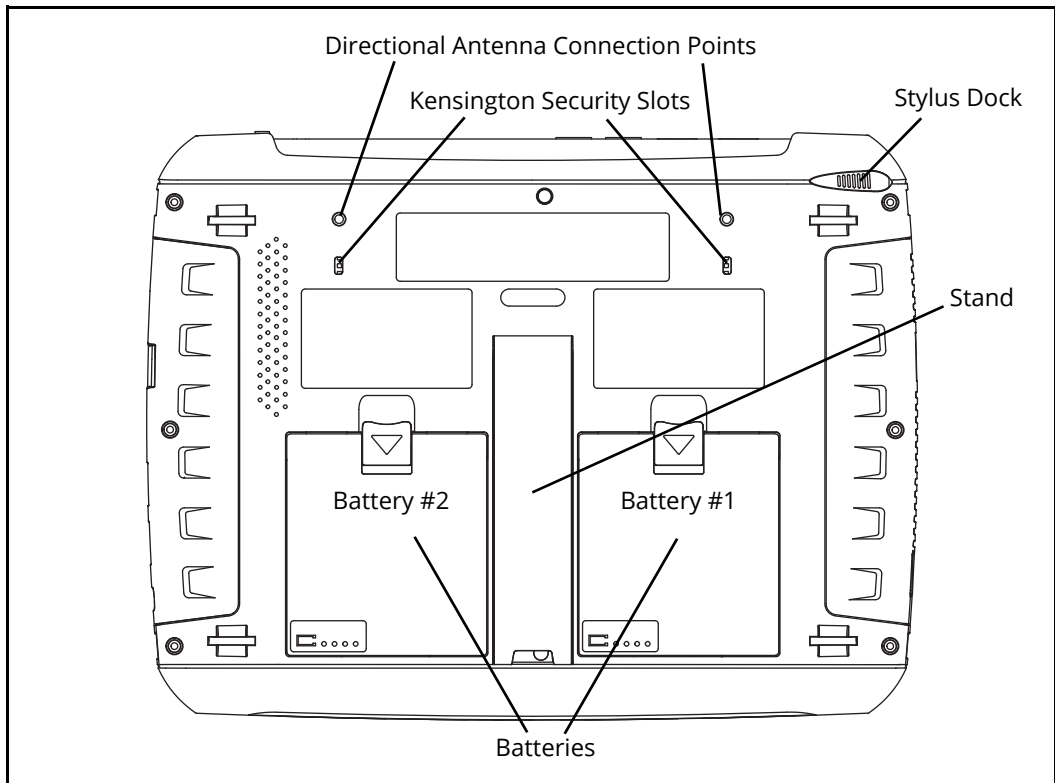

Figure 9. Rear View

- Batteries, see [page 37](#).
- Stand, see [page 17](#).
- Stylus and Dock, see [page 17](#).
- Kensington Security Slot, see [page 47](#).

Stylus

The stylus is docked in the upper right corner of the rear panel. Slide it out to use it; slide it back in for storage.

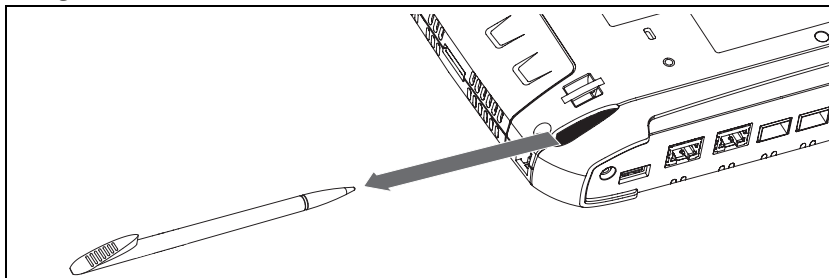

Figure 10. Stylus and Dock

The multi-touch screen is designed for use with a stylus. However, you can also use your fingertip. Your fingernail or a stylus provide more accurate control than the pad of your fingertip. Use of sharp objects or excessive pressure on the multi-touch screen may cause permanent damage.

See also: "Screen Use and Care" on [page 21](#).

Extending the Stand

The stand is a convenient feature for desktop use. To extend the stand, pull at the recessed portion located at the bottom of the stand. To retract the stand, push it back in until it snaps in place.

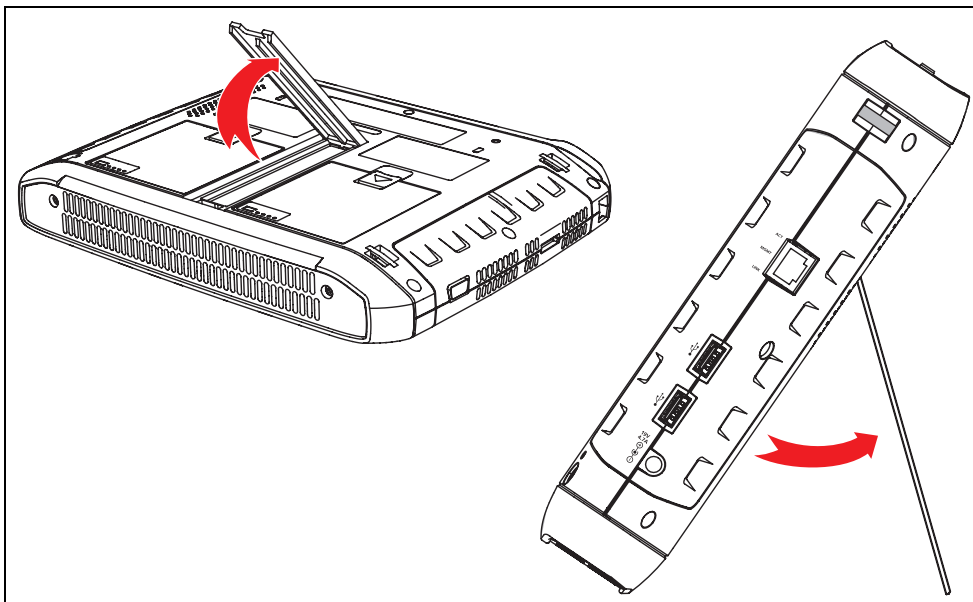

Figure 11. Extending the Stand

Power Modes

Powering On

1. Connect the AC adapter to a power source and to the OptiView XG Network Analysis Tablet. See Figure 12, "Powering On" for the location of the power connector and power button. The batteries are not fully charged before shipment due to transportation regulations.
2. Charge the batteries to full capacity before disconnecting the AC adapter. Charge time is approximately 3 hours. Run time is approximately 2 hours with fully charged batteries.

If running wireless only, the run time is approximately 4 hours.

- If the OptiView XG is powered-on, see the Battery Status Window (see [page 38](#)) to verify that batteries are fully charged.
 - If the OptiView XG is powered-off use the Battery Charge Status LED (see [page 37](#)) or the Battery Charge Indicators on the batteries (see [page 38](#)) to verify that batteries are fully charged.
3. Press the green On/Off button to power-on the OptiView XG.

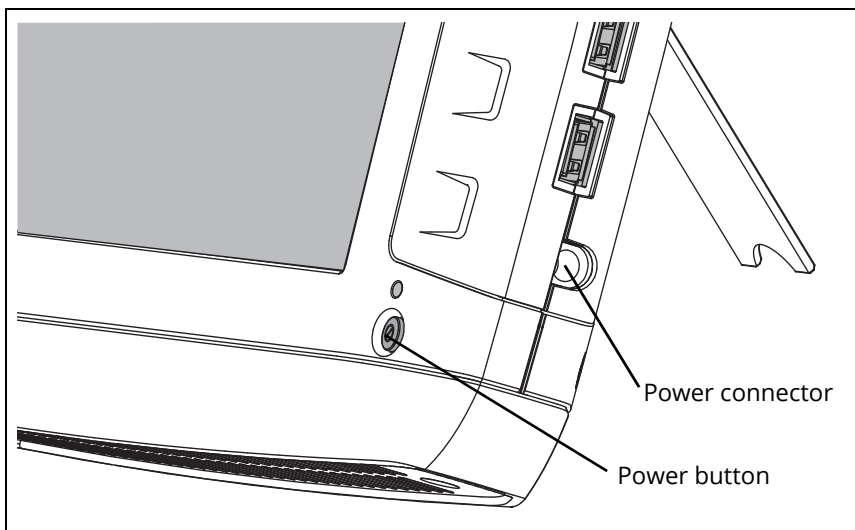

Figure 12. Powering On

The OptiView XG will power-up. The following screens will be displayed during power up:

1. Blank screen.
2. NETSCOUT splash screen.
3. Operating system startup screens.
4. NETSCOUT desktop background.
5. The OptiView XG application.

NOTE

If the wireless only configuration is purchased, the AirMagnet WiFi Analyzer PRO home screen is displayed instead of the OptiView XG application which is shown below. (See Figure 2, “OptiView XG Network Analysis Tablet with Wireless Only Enabled”).

- When power-on is complete, the default dashboard is displayed.

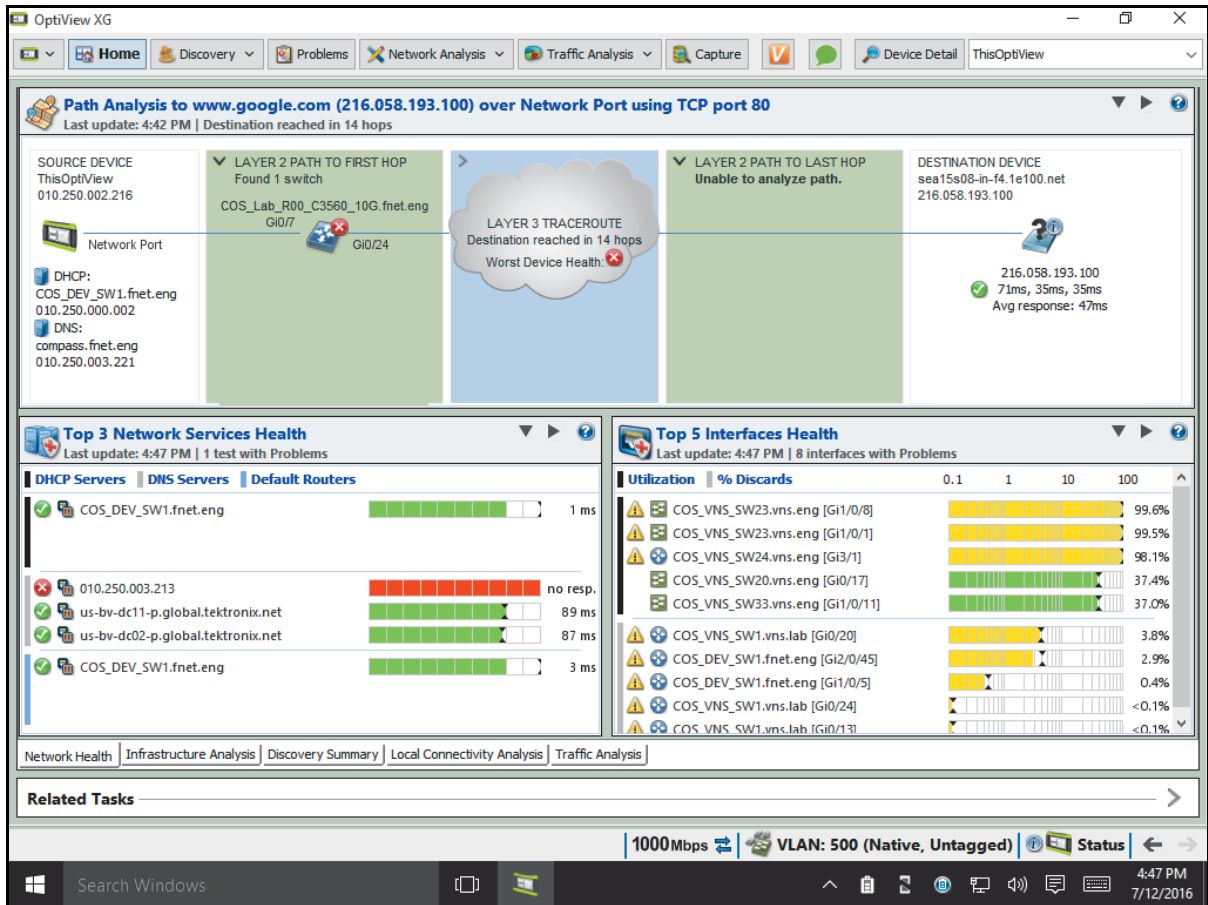

Figure 13. OptiView XG Home Screen

For more information, see “Context-Sensitive Help System” on [page 12](#).

Sleep Mode

In the factory-default configuration, when you press the OptiView’s power button the Windows Sleep sequence is activated, and the unit goes into a low power state. The Power/Charge LED indicator behavior is described on [page 37](#).

To resume from Sleep mode, press the power button.

Two fully-charged batteries will last approximately 36 hours when the OptiView XG is in Sleep mode.

NOTE

Settings that you configure in the OptiView Settings screens are retained through Sleep and Shutdown cycles. Discovery and Traffic Analysis data are not retained.

Powering-Off

If you plan to leave the OptiView XG in Sleep mode while unplugged from the AC adapter for an extended period, power-off the OptiView XG to avoid fully discharging the batteries.

Use the typical Windows Shut Down procedure to power-off your OptiView XG tablet.

When the OptiView XG has been powered-off, battery life is determined by the internal discharge rate of the lithium-ion batteries, which is approximately 5-10% per month.

See also: "Battery Life in Sleep or Shut down Modes" on [page 39](#).

Using the Touchscreen, Stylus, Keyboard, and Mouse

Screen Use and Care

Clean the touchscreen using a soft cloth that has been moistened with mild detergent. Do not spray liquid directly on the touchscreen because the liquid could seep into the OptiView XG housing. Do not use harsh cleaners on the touchscreen.

See also: “Connecting the OptiView XG to a Network” on [page 24](#).

Windows Touchscreen Settings

The OptiView XG uses a standard Windows touchscreen driver. The Multi-Touch Screen supports Windows multi-touch gestures such as flicks and right-click.

You can customize certain tablet PC features in Windows.

NOTE



*Windows 10 uses a different interface for settings than Windows 7. To open the traditional Windows **Control Panel** in Windows 10, right-click (or touch and hold) on the Start button in the lower left corner; then, select Control Panel from the menu. You can also search for “control panel” in the Search Windows box shown in Figure 14, “Windows Search Boxes”.*

The Windows Control Panel and touchscreen settings can be accessed in any version of Windows by searching for the setting keyword in the Windows search box.



Figure 14. Windows Search Boxes

To search for the settings you want to adjust:

1. In Windows 7, select the Windows Start button  to open the search box.
In Windows 10, the search box appears to the right of the Windows Start button .
2. Type in the keyword or name of the setting listed below to open the correct dialog box for that setting.
 - To **Calibrate** the touch screen, search for the **Tablet PC Settings** dialog box. On the **Display** tab, select the **Calibrate...** button, and then, follow the prompts.
 - To adjust **Pen and Touch** settings, search for the **Pen and Touch** dialog box.
 - To adjust **Virtual Keyboard/Input Panel** settings in Windows 7, search for the **Tablet PC Settings** dialog box. On the **Other** tab, use the links to customize **Pen and Touch** and **Virtual Keyboard** (also called **Input Panel**) settings.
 - Refer to “Virtual Keyboard in Windows 10” on [page 23](#) for an overview of the Windows 10 keyboard.

Virtual Keyboard

The virtual keyboard lets you type without a hardware keyboard. This is convenient when you are on-site with the OptiView XG and a hardware keyboard is not connected.

NOTE

The Virtual Keyboards look different depending on whether you have Windows 7 or Windows 10 installed on your OptiView XG.

Virtual Keyboard in Windows 7

1. Touch the left edge of the screen to reveal the edge of the virtual keyboard. Note that you can drag the minimized keyboard up or down if it's in your way.

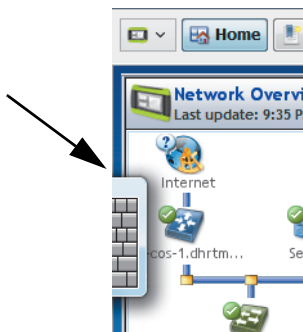

Figure 15. Minimized Virtual Keyboard on an OptiView XG running Windows 7

2. When the edge of the keyboard appears, touch it again and it will come into full view. Touch the keys to type. If desired, you can drag the keyboard to a different location on the screen.



Figure 16. Expanded Windows 7 Virtual Keyboard

3. Select the X to close the keyboard.

Virtual Keyboard in Windows 10

1. Touch the keyboard icon in the Windows 10 task bar (at the bottom of the screen) to open the virtual keyboard.

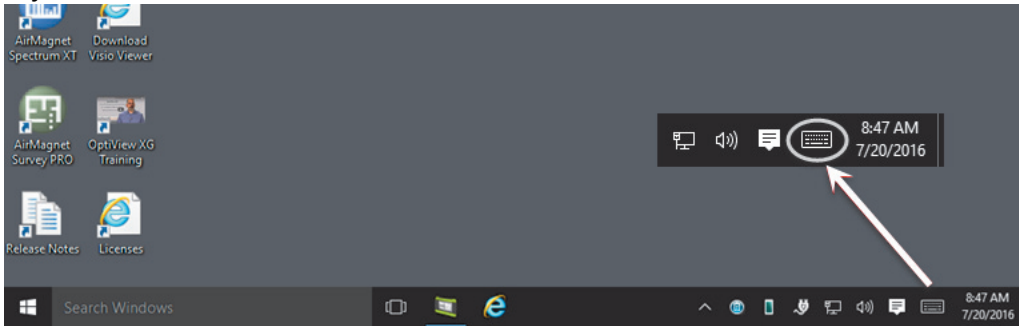

Figure 17. Virtual Keyboard button on an OptiView XG running Windows 10



Figure 18. Maximized Windows 10 Virtual Keyboard

2. Touch the icons circled in the image above to adjust the keyboard's format and position.
3. Select the X to close the keyboard.

Connecting the OptiView XG to a Network

NOTE

For the wireless only configuration, go to “Establishing a Wireless Connection” on [page 26](#).

You can connect the OptiView XG to a network via network ports A, B, C, or D, or via the built-in wireless adapters.

The OptiView XG’s management port can be used for remote control of the analyzer (from a separate network). This lets you control the analyzer from a management network while using the OptiView XG to test a production network.

Establishing a Wired or Fiber Connection

Connect an appropriate cable from one of the OptiView XG’s network ports to the network that you want to test. The OptiView XG will find the active network interface and obtain an IP address. Then it will begin discovering the network.

Network Ports

The OptiView XG has the following network ports:

- Port A: RJ45 Ethernet connector, 10/100/1000 Mbps
- Port B: RJ45 Ethernet connector, 10/100/1000 Mbps
- Port C: 100/1000 Mbps Ethernet over fiber on standard SFP socket
- Port D: 10 Gbps Ethernet over fiber on standard SFP+ socket
- Management Port: RJ45 Ethernet connector, 10/100/1000 Mbps

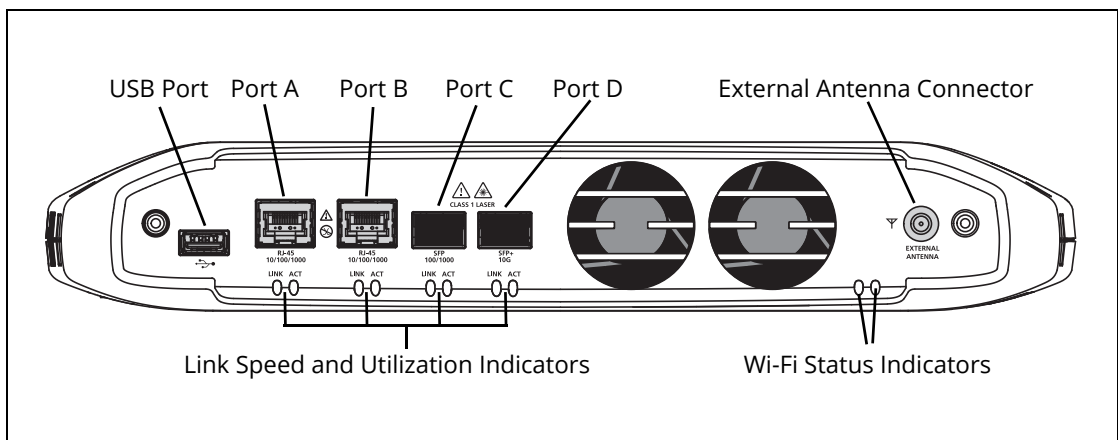

Figure 19. OptiView XG Network Ports

Caution

To prevent equipment damage, do not connect the OptiView XG Port A or Port B to a telephone line or an ISDN line.

Link Speed and Utilization Indicators

There are two link status indicators for each network port: Link Speed (on the left) and Utilization (on the right).

Table 4. Network Port Link Speed Indicator

Color	Link Speed
Green	10 Mbps
Blue	100 Mbps
White	1000 Mbps
Magenta	10 Gbps

Table 5. Network Port Link Utilization Indicator

Color	Link Utilization
Flashing Green	0% - 9%
Green	10% - 50%
Yellow	51% - 80%
Red	81% - 100%

Installing/Removing the SFP or SFP+ Fiber Adapter (Transceiver)

To install an SFP or SFP+ Fiber adapter, remove the protective cap from the adapter and slide the adapter into Port C or Port D. To remove, gently pull the SFP's bail. If the SFP has retention tabs, press and hold the tabs on the sides of the adapter and pull it from the fiber port.

A list of supported SFP and SFP+ modules is given in the specifications on [page 58](#). See www.enterprise.netscout.com for a complete list of supported SFP and SFP+ modules.

Establishing a Wireless Connection

OptiView XG Wireless Capabilities

Wireless capabilities are an option at time of purchase, or may be enabled after purchase. If you purchased wireless capability and you reside in a country for which RF certification has been received, the Wi-Fi adapters were enabled at the factory prior to shipment.

The OptiView XG Network Analysis Tablet includes internal wireless adapters and a spectrum analyzer adapter. They are available to the OptiView XG application and AirMagnet mobility applications for wireless network access and wireless LAN analysis and troubleshooting.

The OptiView XG application can use the Wi-Fi adapter for network access. Once connected, you can analyze and troubleshoot the LAN and wireless network.

The AirMagnet mobility product suite uses the Wi-Fi adapters and the spectrum analyzer adapter for comprehensive 802.11 and RF interference analysis as well as for site survey projects.

The OptiView XG tablet includes two Wi-Fi adapters and one spectrum analyzer adapter: Wi-Fi 1 is for general use as a wireless port or can be used by the AirMagnet applications. Wi-Fi 2 and the spectrum analyzer adapter are reserved for use only by AirMagnet applications.

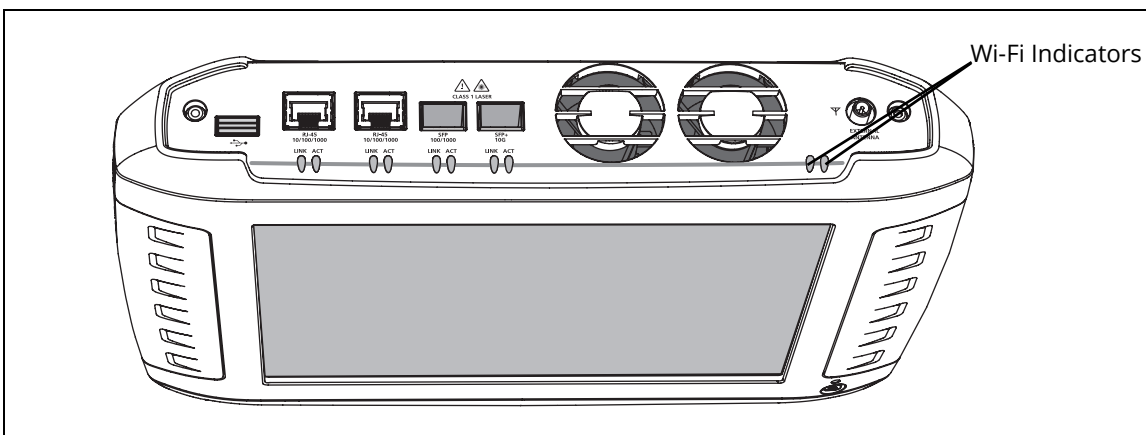

Figure 20. Wi-Fi Indicators

When AirMagnet applications are launched, they will check for the presence of adapters and open a dialog that indicates detected adapters. Check the desired adapter(s) for the current session. It should be noted that AirMagnet products enable the use of multiple adapters for simultaneous channel scan functions. For more information, see “configuring channel scanning for multiple adapters” in the AirMagnet User Guide.

Enabling the Wi-Fi Adapters

If NETSCOUT received approval to enable the Wi-Fi adapters for use in your country before your OptiView XG was shipped to you, and you purchased a model with wireless capabilities, the Wi-Fi adapters are already enabled.

If NETSCOUT received approval to enable the Wi-Fi adapters for use in your country after your OptiView XG was shipped to you and you purchased a model with wireless capabilities, you can enable your Wi-Fi adapters by contacting your sales representative and obtaining a power control key for a nominal fee. To determine whether the Wi-Fi adapters are enabled *and* powered on, select the OptiView Power Control icon in the system tray.



Figure 21. Power Control Icon

Wi-Fi Adapters Not Enabled

If the Wi-Fi adapters have not been enabled, a dialog will be displayed as shown below. To enable the wireless capabilities, enter a power control key.

If NETSCOUT receives approval to enable Wi-Fi adapters in your country after you purchase the OptiView XG, you can call NETSCOUT Technical Assistance Center to obtain a power control key for a nominal fee. Please see “Contacting NETSCOUT” on [page 11](#).

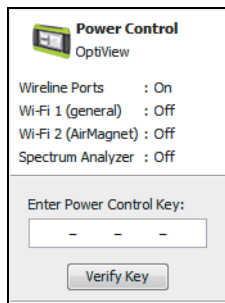
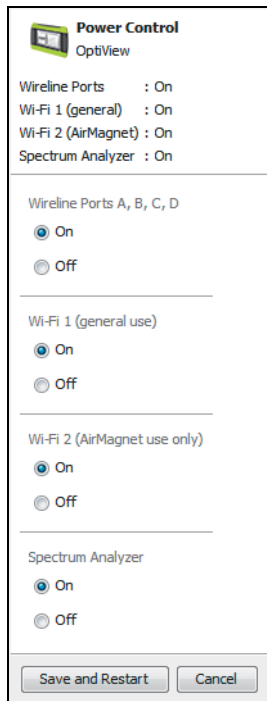

Figure 22. Power Control Dialog

Wi-Fi Adapters Enabled

If the Wi-Fi adapters are enabled, the OptiView Power Control application will open as shown below. Use the application to manage power for the adapters you want to use.



The Wi-Fi adapters and the spectrum analyzer consume small amounts of power, so it's fine to leave them powered-on even when operating on battery power.

Select the "Save and Restart" button to reboot the system and make the changes effective.

Figure 23. Power Control Application

Connecting to Wireless Networks in Windows

On the OptiView XG Network Analysis Tablet, you can view and connect to wireless networks the same way you would on a typical Windows device.

NOTE

This section only applies to the OptiView XG Tablet user interface. It does not apply to the AirMagnet applications. The Wi-Fi profile and security are configured separately on each AirMagnet application.

1. Select the wired or wireless networks list icon in the Windows task bar at the lower right corner of the screen.

-  Wired Windows 7
-  Wired Windows 10
-  Wireless Windows 7
-  Wireless Windows 10

NOTE

The Network icons may appear in different colors depending on the version of Windows you are using, but they are always located in the task bar at the lower right.

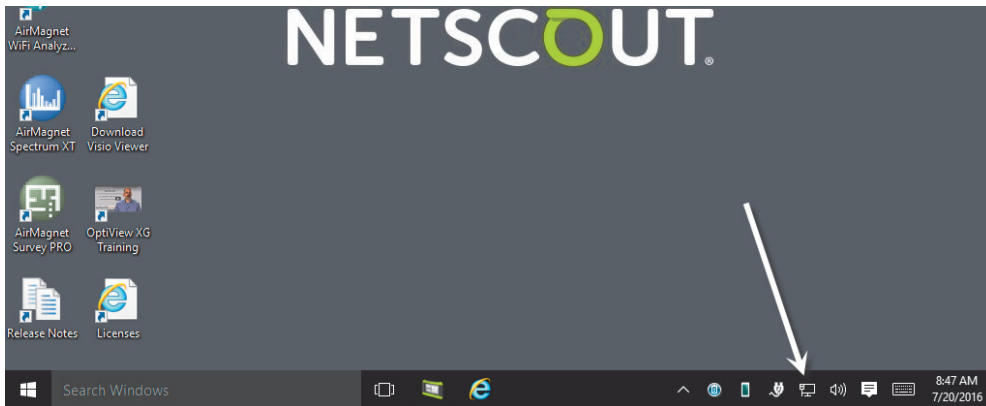

Figure 24. Location of Networks List Icon in the Windows Task Bar

A pop-up displays the available networks.

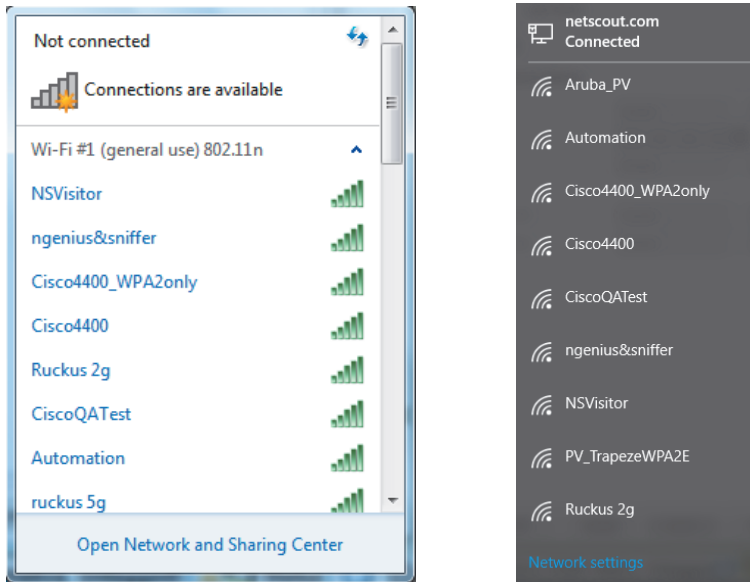

Figure 25. Wireless Networks Pop-up List (Windows 7 left; Windows 10 right)

2. Select a network name from the list to enter security credentials and connect.
3. Select “Open Network and Sharing Center” (in Windows 7) or “Network settings” (in Windows 10) to manage your wired and wireless connection profiles in Windows..

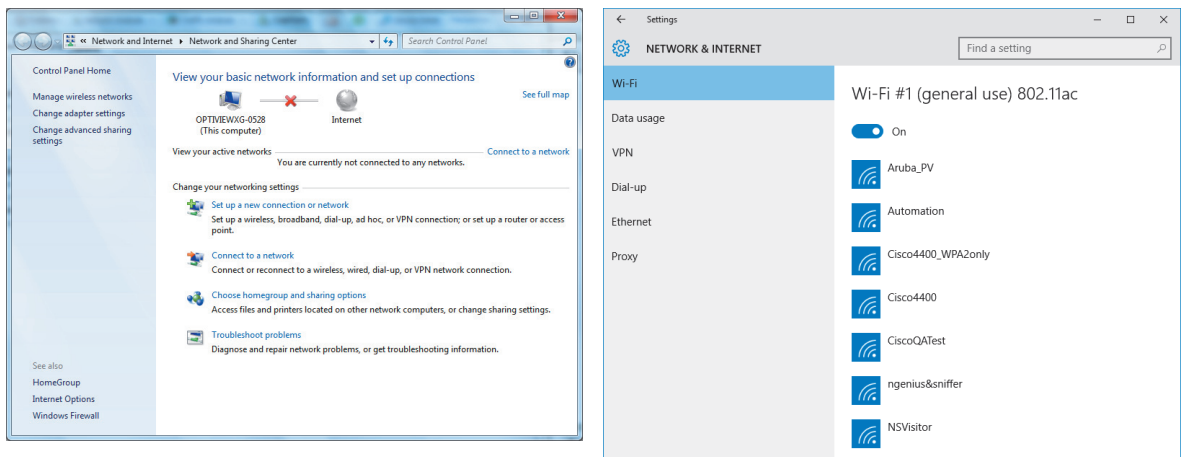

Figure 26. Network Settings (Windows 7 left; Windows 10 right)

Managing Wi-Fi on an OptiView XG Tablet with Windows 7

See “Managing Wi-Fi on an OptiView XG Tablet with Windows 10” on [page 33](#).

NOTE

This section only applies to the OptiView XG Tablet user interface. It does not apply to the AirMagnet applications. The Wi-Fi profile and security are configured separately on each AirMagnet application.

1. Select the **Status** button, which is located at the bottom of the screen. The configuration panel will open.



Figure 27. Status Button

2. Collapse the Network Port section and expand the Wireless Port section using the arrows at the right.

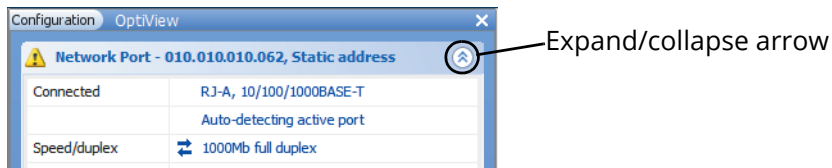

Figure 28. Network Port Status

3. Select the word “Disconnected.” The **OptiView Settings** screen will be displayed, with the **Wireless** icon highlighted at the left edge of the screen.

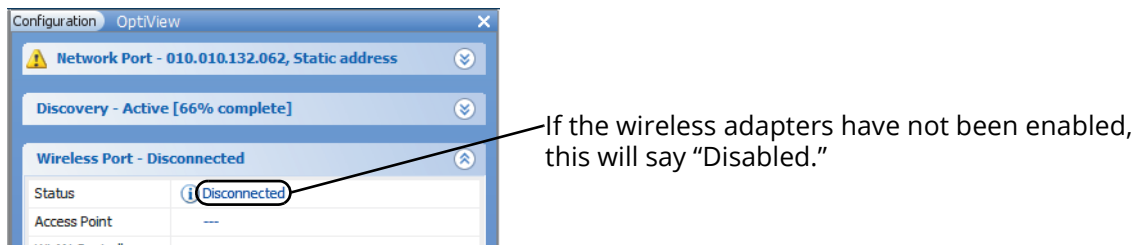

Figure 29. Wireless Port Settings

4. Select the **Manage Wireless Networks** button, and follow the Windows prompts.

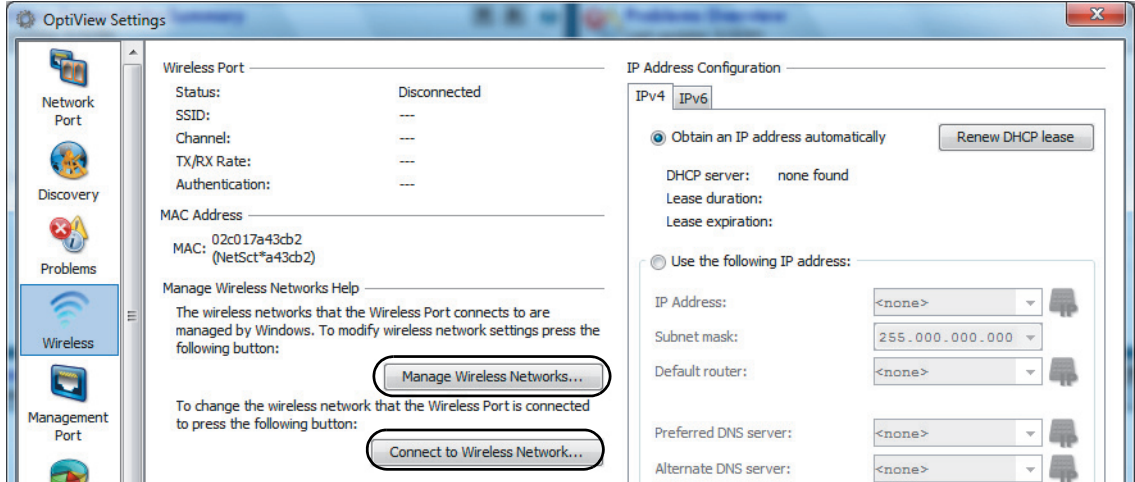

Figure 30. Manage Wireless Networks Button

The OptiView XG connects to networks based on the profile preferences you create.

Managing Wi-Fi on an OptiView XG Tablet with Windows 10

NOTE

This section only applies to the OptiView XG Tablet user interface. It does not apply to the AirMagnet applications. The Wi-Fi profile and security are configured separately on each AirMagnet application.

Viewing Wireless Settings with Windows 10

1. Select the **Status** button, which is located at the bottom of the screen. The configuration panel will open.



Figure 31. Status Button

2. Collapse the Network Port section and expand the Wireless Port section using the arrows at the right.

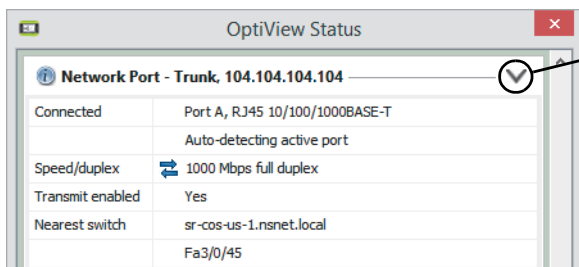

Figure 32. Network Port Status

3. Select the word "Disconnected." The **OptiView Settings** screen will be displayed, with the **Wireless** icon highlighted at the left edge of the screen.

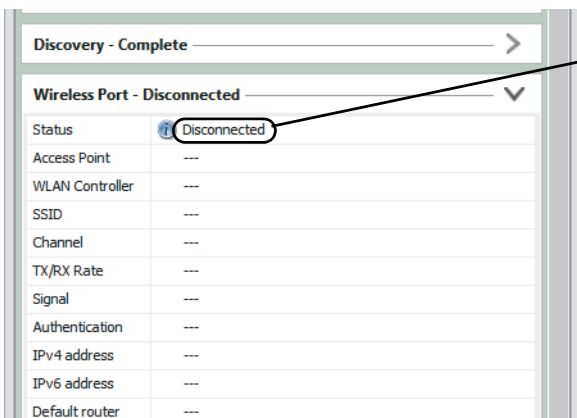

Figure 33. Wireless Port Settings

The Wireless Settings screen displays additional information regarding the current wireless status.

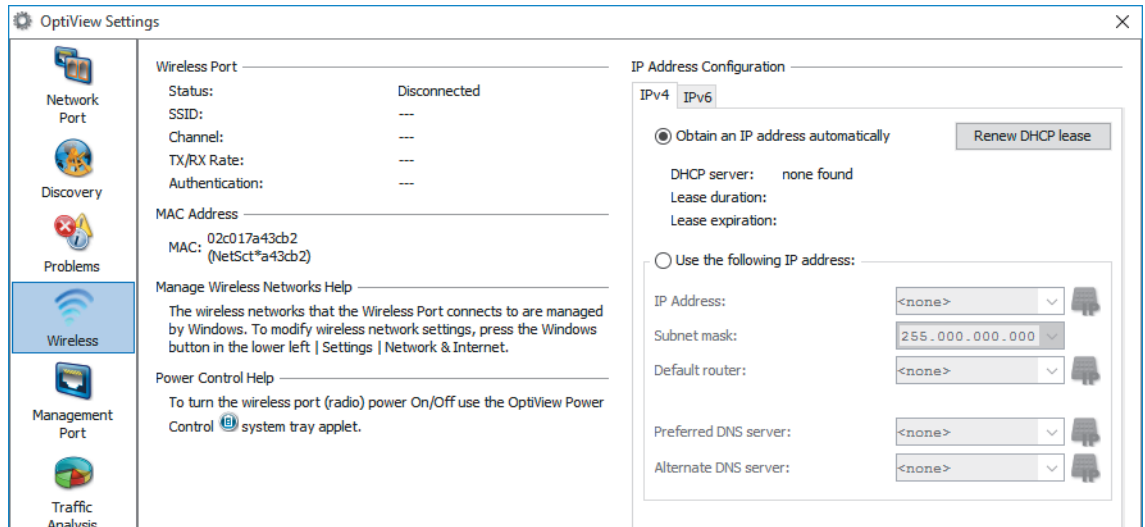



Figure 34. Windows 10 Wireless Settings

Managing Wireless Network Profiles with Windows 10

1. Select the Windows Start button  in the lower left corner of the screen, and then, select **Settings**.
2. In the Windows 10 Setting menus, select **Network & Internet**.

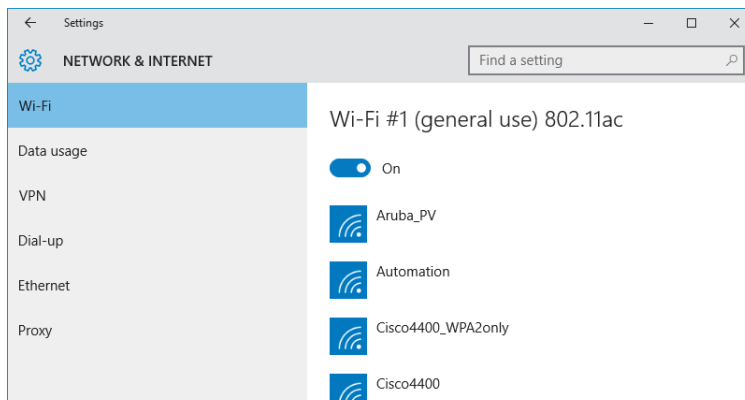

Figure 35. Windows 10 Network & Internet Settings

3. Select a wireless network to manage its credentials.

Wi-Fi Indicators

Each of the two Wi-Fi adapters has a single link status indicator. The LED illuminates when the Wi-Fi adapter is in use. The LED's color indicates the link speed (or that the Wi-Fi adapter is in use by an AirMagnet application). The LED flashes to indicate traffic is present on the link.

Table 6. Wi-Fi Indicator

Color	Link Speed	Standard
Green	up to 11 Mbps	802.11b
Blue	up to 54 Mbps	802.11a/g
White	up to 300 Mbps	802.11n/ac, with one or two spatial streams
Magenta	450 Mbps or more	802.11n/ac, with three spatial streams (3x3)
Amber	Wi-Fi adapter is in use by an AirMagnet application	

Configuring the OptiView XG for Use with Your Network

1. If your network uses a MAC access list, you will need to add the OptiView XG's MAC addresses to the list. See the OptiView XG online help for more information.
2. Configure SNMP community strings and/or credentials to allow the OptiView XG to fully discover and analyze your network.
 - a. Select the top left OptiView button.
 - b. Select the **OptiView Settings** button.

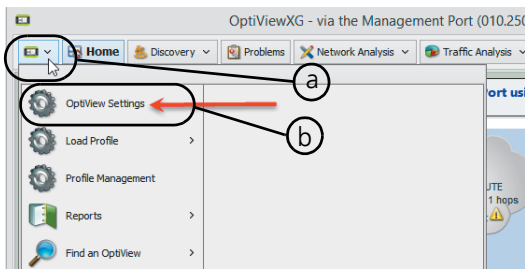

Figure 36. OptiView Settings

- c. Select the **Discovery** button.

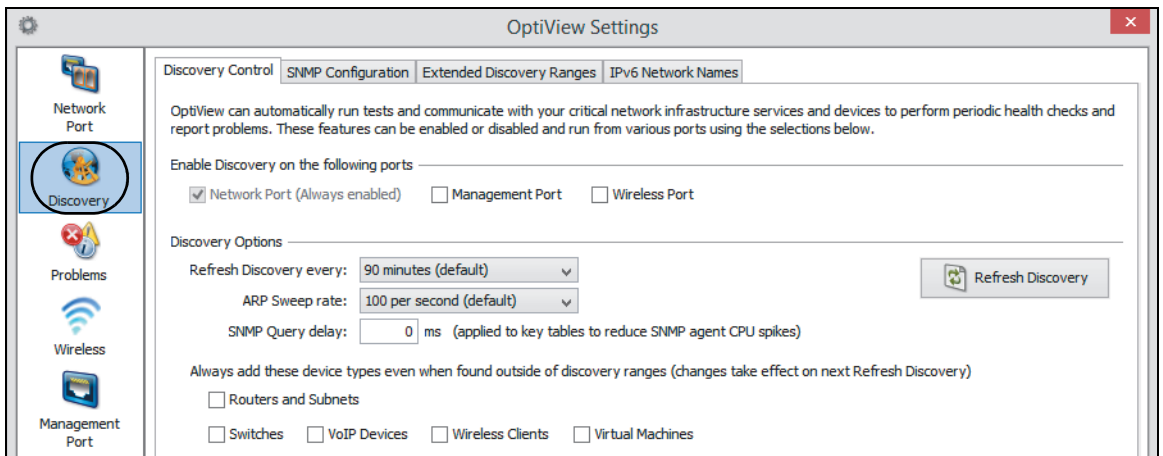

Figure 37. Discovery Settings

- d. Select the **SNMP Configuration** tab.
- e. Add SNMP v1 and v2 community strings and/or add SNMP v3 credentials. Select the Help button on the screen for more information.
- f. Select the **Extended Discovery Ranges** tab to enable discovery of networks beyond the broadcast domain (off-net networks). Select the Help button on the OptiView Settings screen for more information.

Operating the OptiView XG on Battery Power

Battery Operation

The OptiView XG Network Analysis Tablet has two lithium-ion batteries. The batteries are installed into the back of the OptiView XG.

The OptiView XG will run approximately 2 hours using fully-charged batteries. You can hot-swap spare batteries (one at a time if the AC adapter is not connected) to extend run-time.

NOTE

The batteries will last approximately 4 hours with the Wireline Ports turned Off and the wireless adapters turned On. See ["Enabling the Wi-Fi Adapters"](#) on page 27.

Charging the Batteries

Before running the OptiView XG Network Analysis Tablet on batteries, connect the AC adapter to the OptiView XG and charge the batteries. Charge time is approximately 3 hours.

Power/Charge Indicator

The LED next to the OptiView XG power button indicates the power on/off state and the battery charge status.

Table 7. Power/Charge Indicator

LED Color	LED State	Description
Green	On	The OptiView XG is powered-on. Use the battery status window to determine battery charge state. See instructions on page 38 .
Yellow	Flashing	The OptiView XG is in sleep mode or powered-off. The AC adapter is connected, and the batteries are charging.
Yellow	On	The OptiView XG is in sleep mode or powered-off. If the AC adapter is connected, the batteries are fully charged.
Off	Off	The OptiView XG is powered-off (shutdown, not in sleep state) and the AC adapter is disconnected.

Displaying the Battery Charge Status Window

1. The battery status icon is located in the Windows system tray. It appears as a battery, a charging battery, or an electrical plug. Select the icon to open the battery status window.

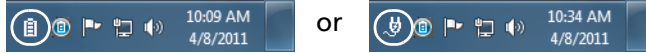
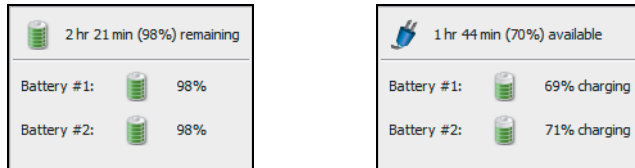

Figure 38. Battery Status Icon

2. The estimated battery capacity is displayed.



Running on battery power.

Running on AC power.

Figure 39. Battery Status Window

3. Touch (or click) the screen outside the battery status window to close the battery status window.

Battery Charge Indicators (on batteries)

The four LEDs on the back of each battery indicate the battery's approximate charge. Press and release the test button. Each illuminated LED indicates an additional 25% of available charge. When the battery's charge level is less than 10%, the left-most LED flashes.

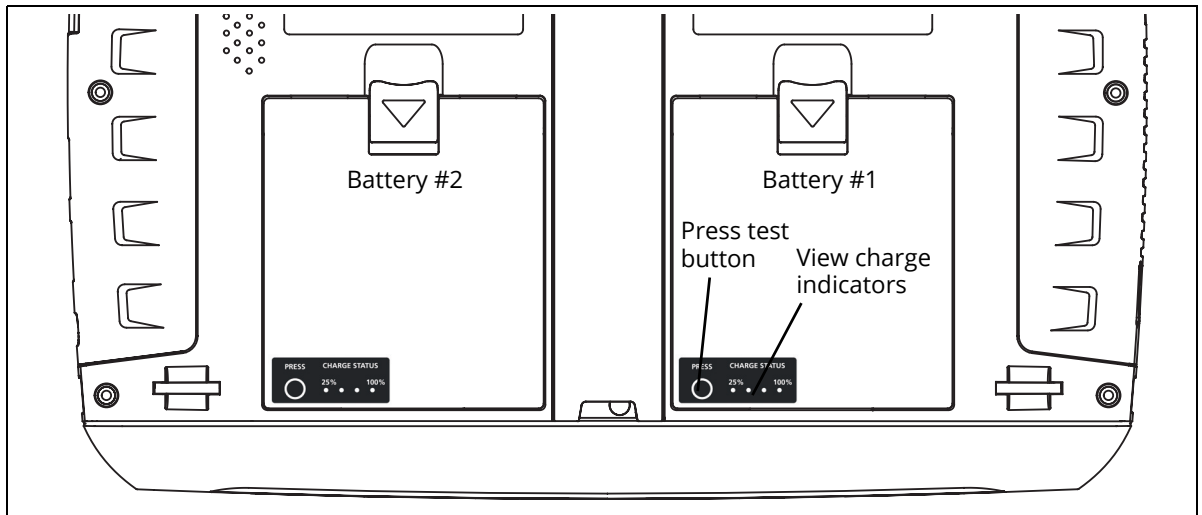

Figure 40. Battery Charge Indicators

Replacing/Hot Swapping the Batteries

To remove a battery, (1) press the release clip and (2) pivot the battery out from the OptiView XG case. To replace, pivot the battery in and press until it snaps into place.

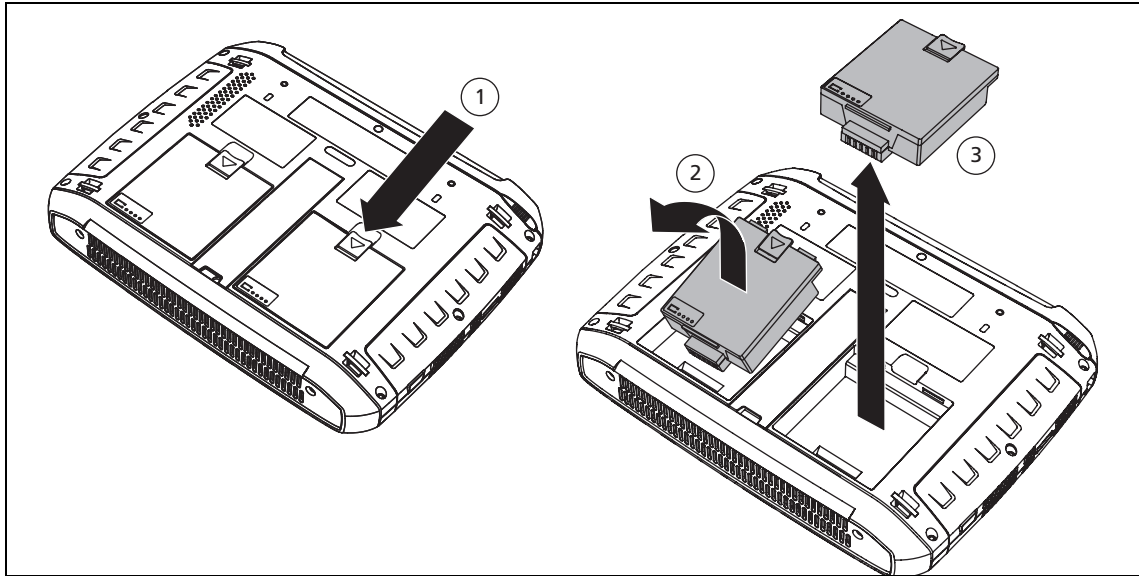

Figure 41. Battery Removal and Replacement

When the AC power adapter is not connected, the OptiView XG is powered by whichever battery contains the most charge. When the batteries have equal amounts of charge, the OptiView XG is powered by both batteries.

The batteries can be hot-swapped. Replacing one battery will not interrupt the OptiView XG's operation as long as the other battery is capable of powering the OptiView XG.

An optional battery kit is available (see [page 7](#)). It contains two batteries, a charging station, and an AC adapter for powering the charging station.

Battery Life in Sleep or Shut down Modes

Two fully-charged batteries will last approximately 36 hours when the OptiView XG is in Sleep mode.

If you plan to leave the OptiView XG in Sleep mode while unplugged from the AC adapter for an extended period, power-off the OptiView XG to avoid fully discharging the batteries.

When the OptiView XG has been powered-off (using Windows Shut down), battery life is determined by the internal discharge rate of the lithium-ion batteries, which is approximately 5-10% per month.

Battery Care

To maximize the life of lithium-ion batteries, avoid frequent full discharges. Partial discharges with frequent recharges will make the batteries last longer. Lithium-ion battery technology does not suffer from the “memory effect,” so recharge the batteries whenever it’s convenient. Avoid storing the batteries in a hot environment. For optimal long-term storage, store at about 50% charge, in a cool place.

Extending Battery Operating Time

In its default configuration, the OptiView XG will operate for approximately two hours with fully-charged batteries.

When only using the wireless adapters to connect to the network (not using Network Ports A, B, C, or D) you can approximately double operating time by switching off power to the network ports. You may want to do this when using the following (optional) applications for an extended period of time for field operations:

- AirMagnet WiFi Analyzer PRO
- AirMagnet Spectrum XT
- AirMagnet Survey PRO

To Switch Off Power to Network Ports A, B, C, and D

1. Select the **OptiView Power Control** icon from the System Tray.



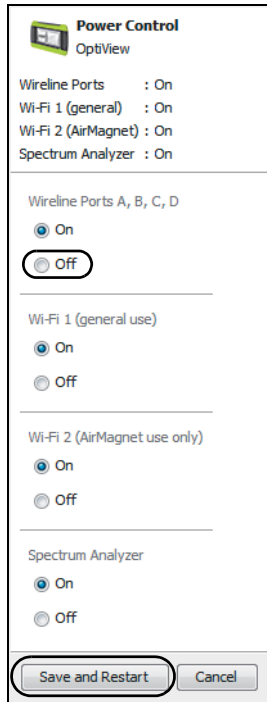

The **OptiView Power Control** screen will appear, as shown.

2. Switch off **Wireline Ports A, B, C, and D**. This will approximately double battery operation time.

3. The system must reboot to make the change. Select the **Save and Restart** button.

NOTE

Remember to switch on Wireline Ports A, B, C, and D before attempting to use the Network Ports!

Connecting External Devices

Keyboard, Mouse, Flash Drive, Printer, and Other USB Devices

You can connect an external keyboard, mouse, flash drive, hard drive, or printer to the OptiView XG's USB ports. Windows will automatically recognize the devices and make them ready to use. See [page 14](#) and [page 15](#) for the locations of the USB ports.

External eSATA Hard Drive

You can connect an external eSATA drive using a shielded cable with a length of one-half meter or less. Restart Windows or use **Control Panel>Device Manager>Action>Scan for Hardware Changes** to cause Windows to recognize the drive. Note that the eSATA connector does not supply power. An external power supply must power the eSATA drive. See [page 15](#) for the location of the eSATA port.

External Antenna

The OptiView XG normally uses its internal antennas. When using AirMagnet applications (e.g. for locating rogues or performing spectrum analysis) you can attach and switch to an external antenna. See [page 24](#) for the location of the external antenna connector.

The optional omni-directional antenna offers better scanning sensitivity when using AirMagnet Spectrum XT.

The optional directional antenna can be used in conjunction with AirMagnet Wi-Fi Analyzer PRO and Spectrum XT applications for increasing signal sensitivity when locating devices.

The directional antenna can be attached to the OptiView XG as shown in Figure 42, "Attaching and Swiveling the Directional Antenna."

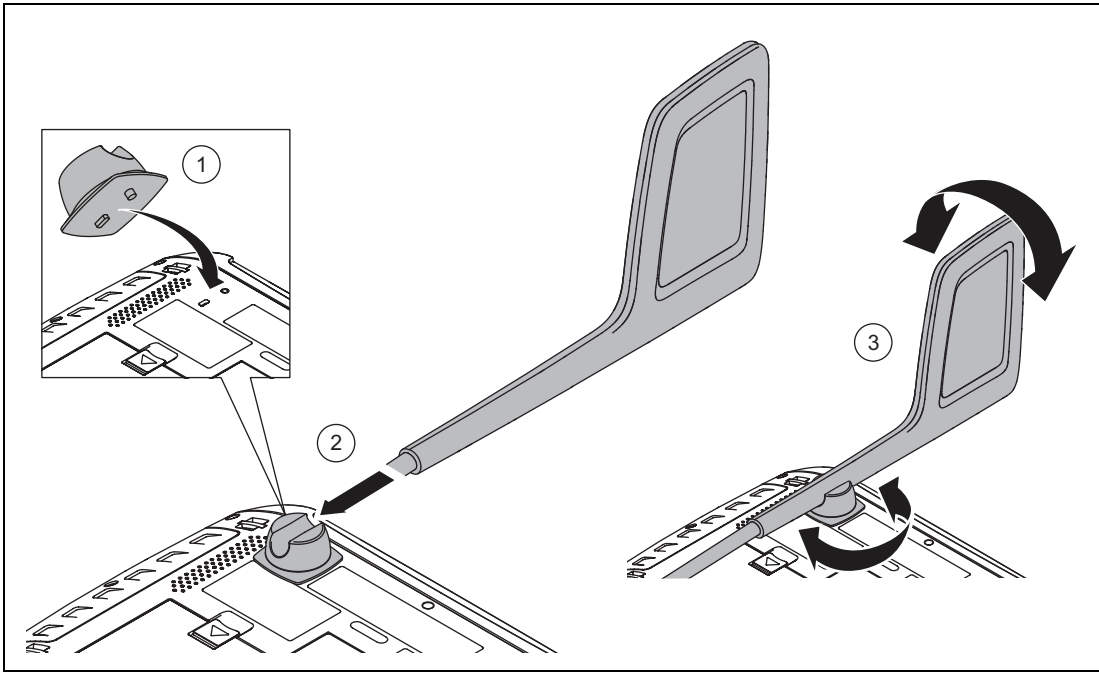

Figure 42. Attaching and Swiveling the Directional Antenna

Power Connector

Connect only the supplied AC adapter to the power connector. Connection of any other power source may damage the OptiView XG. See [page 18](#) for the location of the power connector.

VGA Port for External Monitor

You can connect an external monitor or projector to the VGA port. When connecting to a projector, go to the Windows Control Panel and select **Connect to a projector** under the **Hardware and Sound** heading. See [page 15](#) for the location of the VGA port.

Controlling the OptiView XG from a Remote Computer

NOTE

This section only applies to the OptiView XG user interface. It does not apply to the AirMagnet applications.

The Remote User Interface application lets you initiate remote sessions with OptiView units over a TCP/IP connection. The software includes a browser that helps you easily find OptiView units and initiate remote sessions.

Remote PC Requirements

Operating Systems:

- Windows® 7 Professional with SP1, 32 bit and 64 bit
- Windows 8.1 (32 bit and 64 bit)
- Windows 10

Operating System Languages:

- English, German, Japanese, Simplified Chinese

Installing the Remote User Interface

The remote user interface software may be installed from the supplied OptiView Resource flash drive, or from the OptiView XG's web server home page.

Install from Flash Drive

To install from the flash drive, insert the flash drive in the remote PC's USB port and follow the prompts.

Install from the OptiView XG's Home Page

To view the OptiView XG's Home page, enter the OptiView XG's IP address in your PC's web browser. Then select the **Install Remote UI** button.

Using the Remote User Interface to Access the OptiView XG User Interface

Launch OptiView Browser

The first step in using the Remote User Interface is to launch the OptiView Browser. Double-click the desktop icon or select it from the Windows Program Menu. It is in the NETSCOUT program group. The OptiView Browser will launch, and a list of the analyzers in the local network will be displayed.

Initiate a Remote Session

To initiate a remote session with an OptiView, double-click it in the search results window.

To see an OptiView that is not in the broadcast domain, enter the IP address of the unit in the search bar of the OptiView Browser.

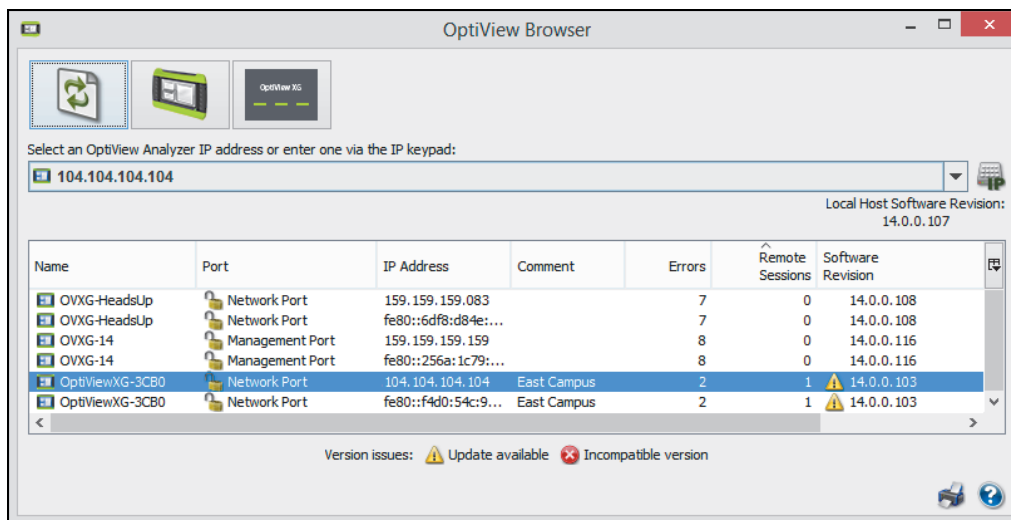

Figure 43. OptiView Browser Window

Once you've established a connection, you can close the OptiView Browser window if desired. This will not terminate the remote session.

Encrypting Data Over the Remote User Interface

A computer can initiate a remote session with an OptiView (see [page 44](#)). Data sent to and from the remote analyzer can be encrypted. The OptiView XG uses the Advanced Encryption Standard (AES) 128 bit encryption algorithm. The encryption key can be entered in Hex or ASCII. ASCII is provided for ease of remembering the encryption key. An encryption key containing less than 128 bits (16 ASCII characters) will be padded with 0's.

When an encryption key has been set, each user attempting to open a remote UI session with the OptiView XG will be prompted to enter the encryption key. When a remote encrypted session has been established via a remote PC, the encryption key will be remembered on the remote PC (and it will not have to be entered again).

Caution

For security reasons, encryption should be set directly on the OptiView XG and not through a remote session. A remote UI could be capturing packets (and the transmitted encryption key) while another remote UI is setting the data encryption.

To Set Up Remote User Interface Encryption

1. Select the **Link Status** button.



2. Select the **Access** button.
3. Select the **Remote Access** tab.

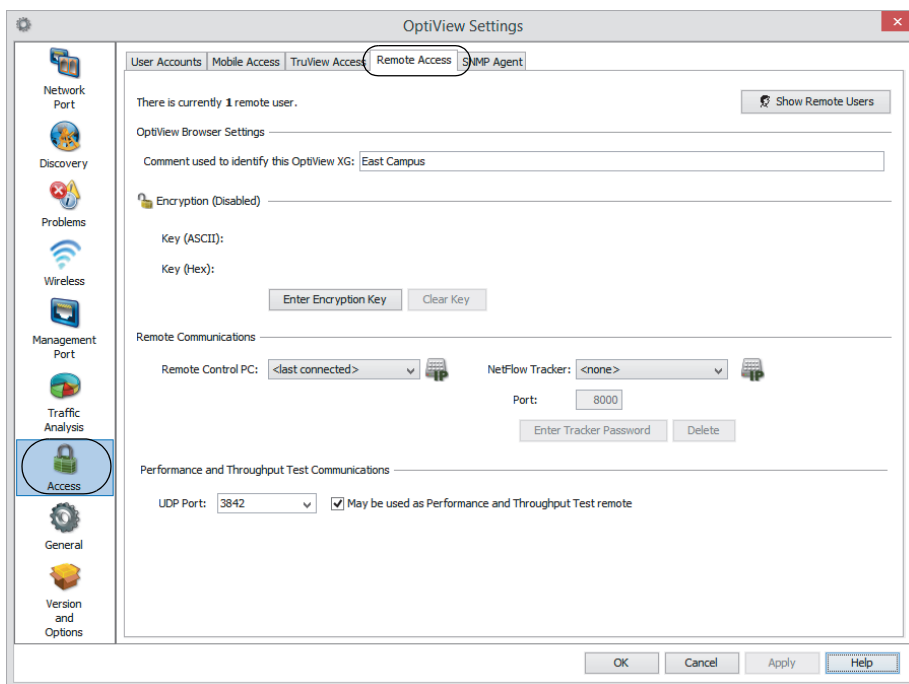

Figure 44. Remote Access Settings

4. Press the **Enter Encryption Key** button.
5. Select ASCII or Hexadecimal and enter the key. This key will be required when a remote user attempts to initiate a remote session.

You can clear the encryption key by pressing the **Clear Key** button.

Remote Connection Termination

To terminate a remote connection, close the OptiView Remote User Interface window on the remote computer.

The remote connection will be terminated if the OptiView XG's MAC or IP address is changed, encryption is changed, cable test is executed, the OptiView XG is switched to receive-only mode, or if the TCP/IP session is terminated for any reason.

Security

It is common practice to leave the OptiView XG powered-on and connected to a network. This lets you become familiar with devices on the network and normal traffic patterns. However, it is important to secure the OptiView XG from theft and unauthorized use.

You can physically secure the OptiView XG in place using a Kensington® lock. You can lock the OptiView XG by locking Windows. And you can create user accounts with specific privileges.

Physical Security: Kensington Lock

Kensington security slots are provided on the OptiView XG housing. You can reduce the chance of theft by purchasing a Kensington lock and using it to secure the OptiView XG in place.

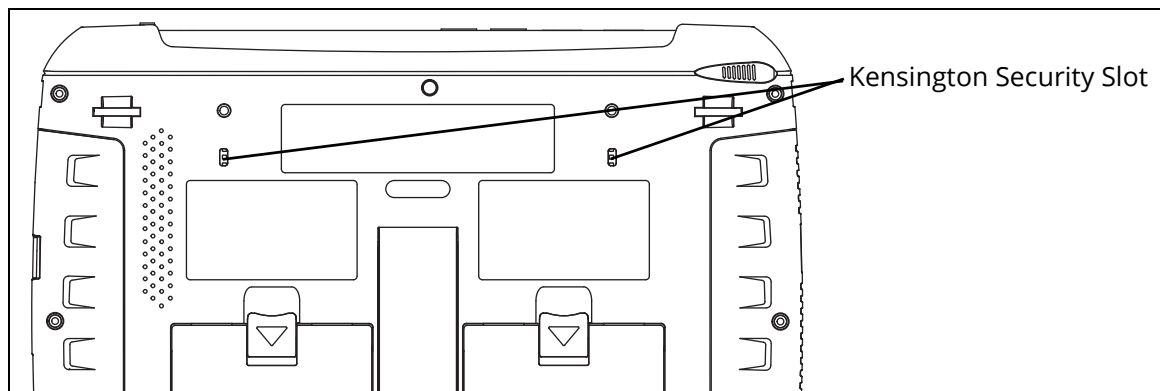

Figure 45. Kensington Security Slot

Controlling Access to the OptiView XG

Locking Windows

When the OptiView XG is connected to a network and running, and you want to leave it unattended, you can restrict access by locking Windows. Press Ctrl+Alt+Del and choose **Lock the computer**. However, this only provides protection if you have set up a user account in Windows. Otherwise, the OptiView XG can be unlocked by pressing the Enter key.

OptiView XG User Accounts

To control access to certain features of the OptiView XG, set up a User Account for each user. Permissions can be set for each user. The **admin** account must be enabled prior to setting up additional user accounts.

To Set Up User Accounts

1. Select the **Link Status** button to display the OptiView Settings screen.



2. Select the **Access** button.
3. Select the **User Accounts** tab.

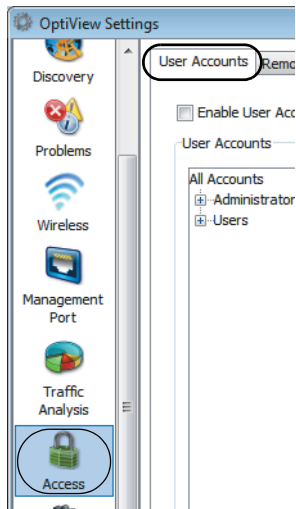

4. Expand the Administrators tree and select the **admin** account.

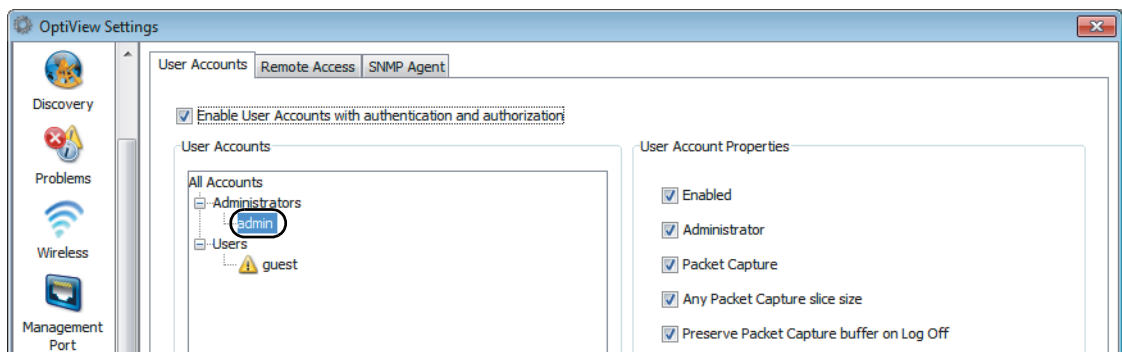

Figure 46. User Accounts Tab

5. Select the **Create Password** button and enter a password. The password field can be up to 40 characters in length. All characters (including spaces) are allowed for the password field.

6. Select the **Enabled** check box under User Account Properties.

Choose options under User Account Properties by checking the check boxes. Normally, all of the boxes are selected for the administrator account. See the OptiView XG online help for descriptions of the User Account check boxes.

7. Select the **Apply** button.

8. *Be sure to select the **Enable User Accounts with authentication and authorization** check box!* When this box is not selected, all user accounts are disabled.

- You may now create additional user accounts if desired. Select the **guest** account if you'd like to use it, or select the **Add** button to create new accounts. The Account name and password fields can be up to 40 characters in length. All characters (including spaces) are allowed for both the Account and password fields.

9. Select the **OK** button.

The user name ("admin" in this case) is displayed in the OptiView title bar.

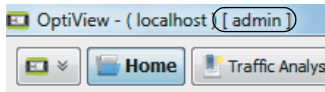

Figure 47. User Name in Title Bar

An icon is displayed to the left of an account name to indicate that the user is logged-in.

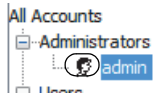

Figure 48. Logged In Icon

To log off, close the OptiView application by selecting the "X" in the upper right corner or by typing Alt+F4. You will need to log in (as admin or a user) whenever you re-start the OptiView XG Network Analysis Tablet or the OptiView application.

- You can create up to 32 user accounts.
- For remote users, the encryption challenge occurs before the login challenge.

Removing and Replacing the Hard Drive

The hard drive can be removed from the OptiView XG for secure data management.

⚠ Caution ⚠

To prevent damage to the OptiView XG and/or the removable hard drive, use standard ESD (electrostatic discharge) control procedures and equipment.

Removing the Hard Drive

The analyzer's "Computer name" is stored on the hard drive. You can view the Computer name by following the instructions in "Changing the Computer Name" on [page 51](#). If desired, make note of the analyzer's Computer name so you can restore it after replacing the hard drive.

1. Power-off the OptiView XG by selecting **Shut down** in Windows.
2. Disconnect all cables from the OptiView XG.
3. Use a Phillips screwdriver to remove the two screws that secure the bottom panel.
4. Slide the hard drive out.

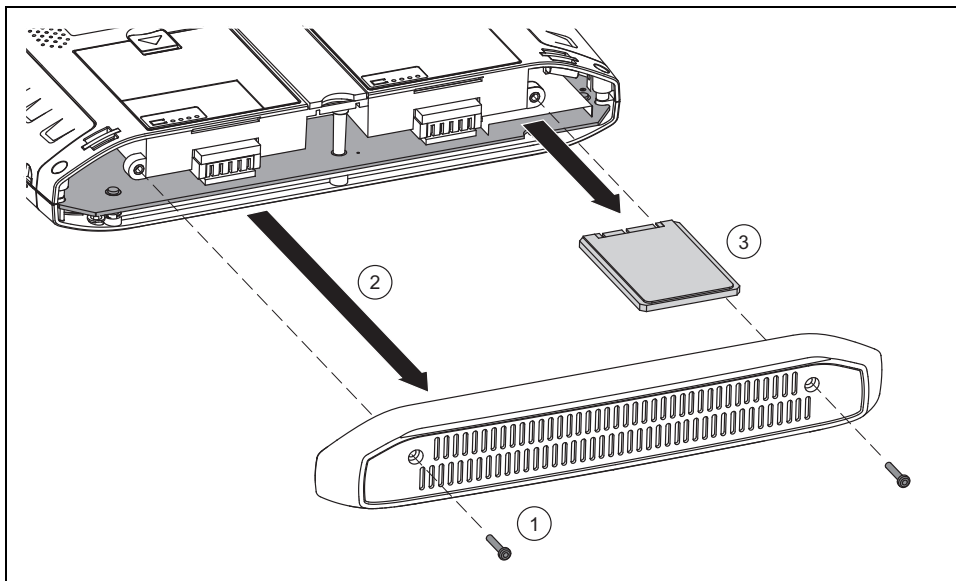

Figure 49. Replacing the Hard Drive

Replacing the Hard Drive

To replace the hard drive, reverse the preceding procedure.

The touchscreen calibration data is stored on the hard drive. You will need to re-calibrate the touchscreen after replacing the hard drive. See “Windows Touchscreen Settings” on [page 21](#).

Changing the Computer Name

The analyzer’s name is stored on the hard drive. You can change the analyzer’s name as follows.

In Windows 7:

1. Select the Start button.
2. Right-click (or touch and hold) **Computer**.
3. Select **Properties**.
4. Select **Change settings** in the Computer name, domain, and workgroup settings section.
5. Type in the new name, and select **Apply**.

In Windows 10:

1. Right-click (or touch and hold) on the Windows Start button  in the lower left corner.
2. Select **System**.
3. Select **Change settings** in the “Computer name, domain, and workgroup settings” section.
4. Type in the new name, and select **Apply**.

Cleaning

Clean the OptiView XG housing, the touchscreen, and the batteries using a soft cloth that has been moistened with mild detergent. Dry with a soft cloth. Do not spray liquid directly on the OptiView XG or the batteries. Do not use harsh cleaners. Do not immerse.

Troubleshooting

If the OptiView XG is not operating as expected, refer to this table for possible causes and solutions.

Table 8. Troubleshooting Guide

Problem	Possible Cause & Solution
Cannot establish a network connection.	The OptiView XG's MAC addresses have not been added to the network's MAC access list.
The OptiView XG fails to get an IP address.	<p>There may be no connectivity to a DHCP server on the link. This could be caused by a DHCP server that is not responding to requests, in which case you would want to investigate the health of the DHCP server.</p> <p>If the analyzer is connected to a trunk port, ensure that the selected VLAN has connectivity to an operational DHCP server, or switch to a different VLAN.</p> <p>Instructions for switching to a different VLAN:</p> <ol style="list-style-type: none"> 1. Select the Link Status button. This opens the OptiView Network Port Settings screen. 2. In the Active VLAN Configuration section, select a VLAN that has connectivity to a DHCP server. 3. Select the OK button at the bottom of the screen.
Cannot establish a Wi-Fi connection.	Enable Wi-Fi adapters. See page 26 .
Cannot establish a network connection on network ports A, B, C, or D.	Enable the Network Ports by switching on power to Network Ports A, B, C, and D. See page 40 .
The OptiView XG is not reporting all of the expected networks, devices, and related detail.	<p>To ensure successful discovery both on-net and off-net, it is critical that you configure Discovery. Select the OptiView button (in the upper left corner of the display), then select the OptiView Settings button. Select the Discovery button (at the left side of the screen).</p> <ol style="list-style-type: none"> 1. To ensure access to the information (SNMP-MIBs) on the devices' SNMP agent, configure the SNMP credentials on the SNMP Configuration tab. 2. Often the devices' SNMP agents are connected to a different subnet than the one to which the OptiView is connected. These SNMP or Management subnets need to be configured on the Extended Discovery Ranges tab. 3. To allow the OptiView to discover networks beyond the subnet to which it is connected, configure the remote subnets for discovery using the Extended Discovery Ranges tab.

Windows Restore Options

In the event the Windows operating system becomes unstable, there are two methods for restoring stability.

- Windows System Restore restores the Windows configuration to an earlier point in time without erasing your data files.
- Windows System Recovery erases all data files and returns the Windows system to its original condition. Instructions are provided for backing up your data files before they are erased.

Windows System Restore

The Windows operating system creates a restore point whenever you install new software. This lets you restore the Windows configuration to an earlier point in time if desired. For example, if you install a driver that when accessed, causes the system to hang, you can restore the Windows operating system using Windows System Restore.

Restoring Windows Configuration from a Previous Windows 7 Restore Point

1. Select the Windows button, then select **Control Panel**.

In Windows 10, right-click (or touch and hold) on the Windows Start button  in the lower left corner, and then, select **Control Panel** from the menu.

2. In the search box, type **System Restore**.
3. Select **Restore system files and settings from a restore point**.
4. Follow the prompts.

Windows System Recovery

In the event the OptiView XG's operating system becomes unstable, and you want to return the OptiView XG to its factory default condition, you can restore the hard drive using the System Recovery utility. This will effectively erase changes that were made since the OptiView XG left the factory. It will leave the OptiView XG's operating system and file system in a known, working state.

Caution

Performing a System Recovery will

- Erase all report, capture, and other data files
- Erase all OptiView XG user accounts and passwords
- Remove all user-installed applications
- Return the OptiView XG to its factory default configuration

The OptiView XG's MAC address, purchased software options, and OptiView Power Control settings will be preserved.

⚠ Caution

The OptiView XG could be rendered inoperable if the System Recovery process is interrupted. The AC adapter (not batteries) should be used to power the OptiView XG during the recovery process.

Windows 7 Back Up and Recovery Procedure

NOTE

The following describes Windows 7 procedures. If you have Windows 10 installed on your OptiView XG, skip to [page 55](#).

Back Up Your Files

If you want to keep any files that currently exist on the OptiView XG's hard drive, use Windows Backup to save them to an external drive. You will need to deselect the "postgres" user account from the backup.

1. Select the Windows button, then select **Control Panel**.
Set the view control to **View by: Small icons**.

2. Select **Backup and Restore**.

Note that if you have previously set up a backup, the "Set up backup" button will not appear on this screen. In that case you will need to choose **Control Panel>Recovery>Advanced recovery methods>Reinstall Windows>Back up now** and then proceed to step 5.

3. Select **Set up backup**.
4. Choose an external destination drive for the backup.
5. At the screen that says "What do you want to back up?" select **Let me choose** and select **Next**.
6. At the "What do you want to back up?" screen deselect **postgres's Libraries** and deselect **Include a system image....**
7. At the "Review your backup settings" screen ensure that OptiView's Libraries are included and postgres's Libraries are not included.
8. Select **Save settings and run backup**.
9. When the backup completes, disconnect the external drive from the OptiView XG.

Recover Windows System Files

1. Disconnect all cables from the OptiView XG except the AC adapter, the keyboard, and the mouse.
2. Restart the OptiView XG.
3. When the NETSCOUT splash screen appears, press the F8 key multiple times.
4. The Advanced Boot Options screen will appear. Verify that **Repair Your Computer** is selected, then press **Enter**.

5. You can now use the mouse to make your selections. Follow the prompts to choose a language.
6. At the User name and Password window, select the drop-down selector.
7. Select **OptiView** as the User name. You do not need to type anything in the Password box unless you have created a password for this user.
8. Select **OK**.
9. At the Choose a recovery tool window, choose **Reinstall Windows**.

The recovery image will be written to the disk, and the old operating system's directory will be renamed C:\Windows.old. The C:\Windows.old directory consumes several gigabytes of storage space on the disk. Verify that you have already saved any data files you need, then use the Windows Disk Cleanup tool to delete all files (including hidden system files) in the C:\Windows.old directory, as described below.

Post-Recovery File Clean-Up

1. Select the Windows Start Button, then type "free up disk space" in the search box.
2. Choose **Free up disk space by deleting unnecessary files**.
3. In the Drive Selection window, select the C: drive and wait for scanning to complete.
4. Select the **Previous Windows installation(s)** check box.
5. Select the **Temporary Windows installation files** check box.
6. Select or deselect other check boxes as desired.
7. Select **OK**.
8. Select **Delete Files**. The selected files will be deleted.
9. If you previously backed up data files to an external drive, connect the drive and use Windows **Backup and Restore** to restore your data files.

Windows 10 Back Up and Recovery Procedure

Back Up Your Files

1. In Windows 10, select the Windows Start button  in the lower left corner of the screen.
2. Select **Settings**, and then **Update & security**.
3. On the left side, select **Backup**.
4. Touch **Add a drive** to choose an external destination drive for the backup.
5. Follow the prompts to save your backup.

Recover Windows System Files

NOTE

The following process requires that you have a physical keyboard plugged into your OptiView XG Tablet (see "Connecting External Devices" on [page 42](#)).

1. In Windows 10, select the Windows Start button  in the lower left corner of the screen.
2. Select **Power**.
3. Hold Shift key on your keyboard, and select **Restart**.
4. Select **Troubleshoot**.
5. Select **Advanced Options**.
6. Select **System Image Recovery**.

Windows will reboot and display a new dialog.

7. Select **OptiView**.
8. Enter the password if necessary; otherwise, select **Continue**.
9. Select **Next** to use the default recovery option.
10. Select **Next**.
11. Select **Finish**.

Windows will restore the drive and reboot.

Specifications

Physical Specifications

Dimensions (H,W,D)	9.45" x 12.43" x 2.03" (240 mm x 315.7 mm x 51.6 mm)
Weight	5.5 lb. (2.5 kg) with batteries; 4.5 lb. (1.8 kg) without batteries
Kensington Lock	Kensington security slot on rear panel for connection of security cable

Environmental Specifications

Operating Temperature*	32°F to 122°F (0°C to 50°C), up to 40% RH, non-condensing 32°F to 86°F (0°C to 30°C), up to 95% RH, non-condensing
Storage Temperature	-40°F to +160°F (-40°C to +71°C)
Shock and Vibration	Meets requirements of MIL-PRF-28800F for Class 3 equipment
Safety	EN 61010-1 2nd Edition
Altitude	4600 m (15,000 ft.); Storage: 12000 m (39,000 ft.)
Pollution Degree 2	Normally only nonconductive pollution occurs. Temporary conductivity caused by condensation is to be expected.

*Battery charging is disabled when internal temperature rises above 113°F (45°C).

Electrical Specifications

AC Adapter Input	90-264 VAC, 47-63 Hz, 2.0 A max
AC Adapter Output	19 VDC, 4.74 A, 90 W
	⚠ Caution: For safe operation, use only the supplied adapter.
Battery	Two user-replaceable, rechargeable, 45 Watt-hour, lithium-ion battery packs.
Battery Operating Time	2 hr. (typical)
Battery Charge Time*	3 hr. (typical). Charge time depends on residual battery charge and analyzer power consumption while charging batteries.
Display	Color LCD (1024 x 768 pixels) touchscreen
Network Analysis Ports	Two 10/100/1000 Mbps RJ45 Ethernet ports
	1000BASE-FX SFP socket
	10000BASE-X SFP+ socket
Management Port	10/100/1000 Mbps RJ45 Ethernet connector
Supported SFP Modules	100BASE-FX - 1300 nm
	1000BASE-SX - 850 nm
	1000BASE-LX - 1310 nm
	1000BASE-ZX - 1550 nm
Supported SFP+ Modules	10GBASE-LR - 1310 nm
	10GBASE-LRM - 1310 nm
	10GBASE-SR - 850 nm
Fault Tolerance	RJ45 Ports are designed to withstand a maximum of 100 volts.
USB Ports	Three USB 2.0 ports
eSATA Port	eSATA port for connecting external hard drive
Video Port	Standard VGA port for connection to monitor or projector

*Battery charging is disabled when internal temperature rises above 113°F (45°C).

Cables

Cable Types	100 W Unshielded Twisted Pair (UTP) LAN cables. 100 W Shielded or Screened Twisted Pair (SeTP) LAN cables. TIA Category 3, 4, 5, 5e, and 6. ISO Class C, D and E).
Cable Length Measurement	Measurable cable lengths are from 3 feet (0.9 meters) to 500 feet (152 meters). Accuracy: ± 6 feet (± 2 meters). Length measurement is based on Nominal Velocity of Propagation (NVP) for selected cable type.

Wireless Antennas

Internal Wireless Antennas	Seven internal 2.4 GHz, 1.1 dBi peak, 5 GHz, 3.2 dBi peak antennas.
External Omni-directional Antenna*	Antenna, WLAN, omnidirectional, 2.4 & 5 GHz, 802.11 A/B/G, 50 W. Gain: 2.1 dBi (2.45 GHz), 2.4 dBi (4.9 GHz), 2.6 dBi (5.25 GHz), 2.5 dBi (5.875 GHz).
External Directional Antenna*	Antenna, frequency range 2.4 - 2.5 and 4.9 - 5.9 GHz. Minimum gain 5.0 dBi peak in the 2.4 GHz band, and 7.0 dBi peak in the 5 GHz band.
External Antenna Connector*	Reverse SMA

*External Antenna port is receive-only (no transmit).

Wireless Adapters 1 and 2

Data Rate	802.11a: 6, 9, 12, 18, 24, 36, 48 and 54 Mbps 802.11b: 1, 2, 5.5 and 11Mbps 802.11g: 6, 9, 12, 18, 24, 36, 48 and 54 Mbps 802.11n: MCS0-MCS23 (20 and 40 MHz bandwidth) 802.11ac: MCS0NSS1-MCS9NSS3 (20, 40 and 80 MHz bandwidth)
Operating Frequency	2.412 ~ 2.484 GHz (Industrial Scientific Medical Band) 5.15 ~ 5.35 GHz and 5.47 ~ 5.85 GHz
Security	64/128-Bit WEP Key, WPA, WPA2, 802.1x
Transmit Output Power* (Tolerance: ±1.5 dBm)	802.11b: 15.67 dBm@11 Mbps 802.11g: 21.75 dBm@54 Mbps 802.11gn: 22.19 dBm@HT20, MCS23 802.11gn: 22.66 dBm@HT40, MCS23 802.11a: 21.77 dBm@54 Mbps 802.11an: 22.36 dBm@HT20, MCS23 802.11an: 22.32 dBm@HT40, MCS23 802.11ac: 13 dBm@VHT20, MCS8NSS3 802.11ac 13 dBm@VHT40, MCS9NSS3 802.11ac: 22.29 dBm@VHT80, MCS9NSS3
Receive Sensitivity (Tolerance: ±2 dBm)	802.11b: -88 dBm@11 Mbps 802.11g: -74 dBm@54 Mbps 802.11gn: -69 dBm@HT20, MCS23 802.11gn: -67 dBm@HT40, MCS23 802.11a: -73 dBm@54 Mbps 802.11an: -68 dBm@HT20, MCS23 802.11an: -66 dBm@HT40, MCS23 802.11ac: -64 dBm@VHT20, MCS8NSS3 802.11ac: -63 dBm@VHT40, MCS9NSS3 802.11ac: -60 dBm@VHT80, MCS9NSS3

Power Consumption (Typical)	<p>Transmitting (Legacy mode, HT20 mode): 870 mA @5 GHz, 700 mA @2.4 GHz.</p> <p>Transmitting (HT40 mode): 900 mA @5 GHz, 750 mA @2.4 GHz.</p> <p>Transmitting (AC mode @5 GHz) 600 mA @1.2 V, 620 mA @3.3 V</p> <p>Receiving (Legacy mode, HT20 mode): 550 mA @5 GHz, 520 mA @2.4 GHz.</p> <p>Receiving (HT40 mode): 610 mA @5 GHz, 600 mA @2.4 GHz.</p> <p>Receiving (AC mode @5 GHz): 830 mA @1.2 V, 700 mA @3.3 V</p>
-----------------------------	---

*The maximum power setting will vary by channel and according to individual country regulations.

Supported Network Standards

IEEE 10BASE-TX, IEEE 100BASE-TX, IEEE 1000BASE-TX, IEEE 1000BASE-X IEEE 10GBASE-X	RFCs: 1213, 1239, 1285, 1512, 1513, 1643, 2108, 2115, 2127, 2515, 2819, 3592, 3895, 3896, 4188, 4502.
---	---

Compliance Statements

EMC	Complies with IEC/EN61326-1:2006, class A
Safety	Complies with IEC/EN 61010-1:2001, CAN/CSA C22.2 No. 61010-1-04, ANSI/UL 61010-1:2004, EN/IEC 60825-1:2007, EN/IEC 60825-2:2004+ A1:2007
Telephone	The OptiView XG is NOT designed for connection to a telephone network. The OptiView XG is NOT designed for connection to an ISDN line. Do not connect to a telephone network or ISDN line except through a regulatory agency compliant computer network modem device.

Federal Communication Commission and Industry Canada Interference Statement

This equipment has been tested and found to comply with the limits for a Class A digital device, pursuant to Part 15 of the FCC and IC Rules. These limits are designed to provide reasonable protection against harmful interference in a residential installation. This equipment generates, uses and can radiate radio frequency energy and, if not installed and used in accordance with the instructions, may cause harmful interference to radio communications. However, there is no guarantee that interference will not occur in a particular installation. If this equipment does cause harmful interference to radio or television reception, which can be

determined by turning the equipment off and on, the user is encouraged to try to correct the interference by one of the following measures:

- Reorient or relocate the receiving antenna.
- Increase the separation between the equipment and receiver.
- Connect the equipment into an outlet on a circuit different from that to which the receiver is connected.
- Consult the dealer or an experienced radio or TV technician for help.

FCC Caution: Any changes or modifications not expressly approved by the party responsible for compliance could void the user's authority to operate this equipment.

This device complies with Part 15 of the FCC standard(s). Operation is subject to the following two conditions:
(1) this device may not cause interference, and
(2) this device must accept any interference, including interference that may cause undesired operation of the device.

This device complies with Industry Canada licence-exempt RSS standard(s). Operation is subject to the following two conditions:

- (1) this device may not cause interference, and
- (2) this device must accept any interference, including interference that may cause undesired operation of the device.

Le présent appareil est conforme aux CNR d'Industrie Canada applicables aux appareils radio exempts de licence. L'exploitation est autorisée aux deux conditions suivantes :

- (1) l'appareil ne doit pas produire de brouillage, et
- (2) l'utilisateur de l'appareil doit accepter tout brouillage radioélectrique subi, même si le brouillage est susceptible d'en compromettre le fonctionnement.

Under Industry Canada regulations, this radio transmitter may only operate using an antenna of a type and maximum (or lesser) gain approved for the transmitter by Industry Canada.

To reduce potential radio interference to other users, the antenna type and its gain should be so chosen that the equivalent isotropically radiated power (e.i.r.p.) is not more than that necessary for successful communication.

Conformément à la réglementation d'Industrie Canada, le présent émetteur radio peut fonctionner avec une antenne d'un type et d'un gain maximal (ou inférieur) approuvé pour l'émetteur par Industrie Canada.

Dans le but de réduire les risques de brouillage radioélectrique à l'intention des autres utilisateurs, il faut choisir le type d'antenne et son gain de sorte que la puissance isotrope rayonnée équivalente (p.i.r.e.) ne dépasse pas l'intensité nécessaire à l'établissement d'une communication satisfaisante.

OptiView XG Identification Numbers

FCC ID: WA7-43460AC

IC ID: 6627C-43460AC

Exposure to RF Energy

THIS MODEL DEVICE MEETS U.S. AND INTERNATIONAL REQUIREMENTS FOR EXPOSURE TO RADIO FREQUENCY RADIATION.

The OptiView XG is a radio transmitter and receiver. It is designed and manufactured not to exceed the emission limits for exposure to radio frequency (RF) energy set by the Federal Communications Commission of the U.S. Government and by the International Commission on Non-Ionizing Radiation Protection (ICNIRP). The device also meets the European Radio and Telecommunications Terminal Equipment (R&TTE) directive, for protecting the health and safety of the user and other persons.

These limits are part of comprehensive guidelines that establish permitted levels of RF energy for the general population. The guidelines are based on standards that were developed by independent scientific organizations through periodic and thorough evaluation of scientific studies. The standards include a substantial safety margin designed to assure the safety of all persons, regardless of age and health.

Before a device model is available for sale to the public, it must be tested and certified to operate within the limits for safe exposure established by the FCC and international organizations. The tests are performed in positions and locations (e.g., next to the body) as required by the FCC for each model. The FCC has granted an Equipment Authorization for this model device with all reported SAR levels (see below) evaluated as in compliance with the FCC RF emission guidelines.

This device meets RF exposure guidelines when the antennas are positioned at a minimum distance from the body. In order to transmit data or messages, this device requires a quality connection to the network. In some cases, transmission of data or messages may be delayed until such a connection becomes available. Be sure that the recommended distance is observed until the transmission is complete.

The exposure standard for wireless devices employs a unit of measurement known as the Specific Absorption Rate, or SAR. Tests for SAR are conducted using standard operating positions specified by the FCC with the device transmitting at its highest certified power level in all tested frequency bands. The SAR limit set by the FCC is 1.6 W/kg. The international guidelines state that the SAR limit for mobile devices used by the public is 2.0 W/kg averaged over 10 grams of body tissue. SAR values may vary depending on national reporting requirements and the network band. Although the SAR is determined at the highest certified power level, the actual SAR level of the device while operating can be well below the maximum value because the device operates at multiple power levels and uses only the power required to reach the network.

SAR information on this model device is on file with the FCC and can be found under the Display Grant section <http://www.fcc.gov/oet/fccid> after searching on FCC ID: WA7-43460AC.

Europe-EU Declaration of Conformity

This device complies with the essential requirements of the R&TTE Directive 1999/5/EC. This device is a 2.4 GHz wideband transmission system (transceiver), intended for use in all EU member states and EFTA countries, except in France and Italy where restrictive use applies.

In Italy the end-user should apply for a license at the national spectrum authorities in order to obtain authorization to use the device for setting up outdoor radio links and/or for supplying public access to telecommunications and/or network services.

This device may not be used for setting up outdoor radio links in France and in some areas the RF output power may be limited to 10 mW EIRP in the frequency range of 2454 MHz to 2483.5 MHz. For detailed information the end-user should contact the national spectrum authority in France.

Japan

電波法により 5 GHz 帯は屋内使用に限ります

(5 GHz radio band method is limited to indoor use.)

Brazil

Este equipamento opera em caráter secundário, isto é, não tem direito a proteção contra interferência prejudicial, mesmo de estações do mesmo tipo, e não pode causar interferência a sistemas operando em caráter primário.

(This equipment operates on a secondary basis and, consequently, must accept harmful interference, including from stations of the same kind, and may not cause harmful interference to systems operating on a primary basis.)

Korea

EMC Class A Warning:

이 기기는 업무용 (A 급) 전자파 적합기기로서 판매자 혹은 사용자는 이 점을 주의하시기를 바라며, 가정외의 지역에서 사용하는 것을 목적으로 합니다.

EMC Class B Warning:

이 기기는 가정용 (B 급) 전자파적합기기로서 주로 가정에서 사용하는 것을 목적으로 하며, 모든 지역에서 사용할 수 있습니다.

RF Warning:

해당무선설비는 전파혼신의 가능성이 있으므로 인명안전과 관련된 서비스는 할 수 없습니다.

Taiwan

Regulatory Compliance Chinese Warning for Access Points according to rule of LP0002 低功率電波輻射性電機管理辦法

經型式認證合格之低功率射頻電機，非經許可，公司、商號或使用者均不得擅自變更頻率、加大功率或變更原設計之特性及功能。

低功率射頻電機之使用不得影響飛航安全及干擾合法通信；經發現有干擾現象時，應立即停用，並改善至無干擾時方得繼續使用。

前項合法通信，指依電信法規定作業之無線電通信。

低功率射頻電機須忍受合法通信或工業、科學及醫療用電波輻射性電機設備之干擾。

Contacting NETSCOUT

Web: www.enterprise.netscout.com

Email: customercare@netscout.com

Phone: Toll free +1-844-833-3713; International 978-320-2150

For more contact information, visit our website.

Appendix A: Activating the OptiView XG Wired Option

This section describes how to activate a purchased OptiView wired (LAN) features. This procedure only applies to analyzers that were originally purchased with the OptiView XG wireless only option.

1. From the OptiView XG desktop, select the OptiView XG icon as shown below.

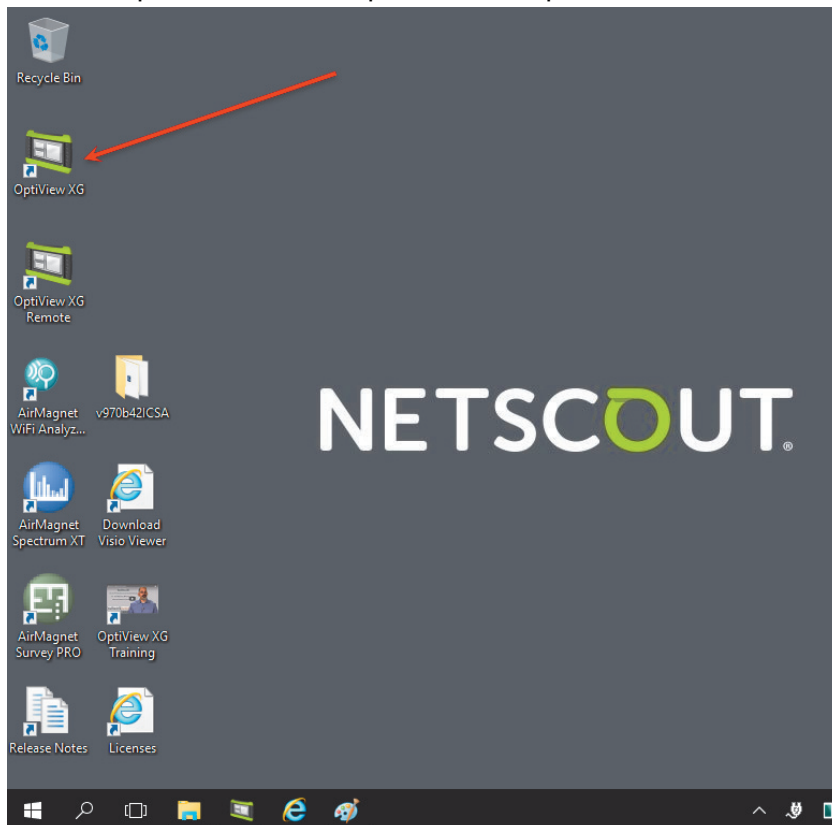

2. Select the OptiView icon to open the menu.

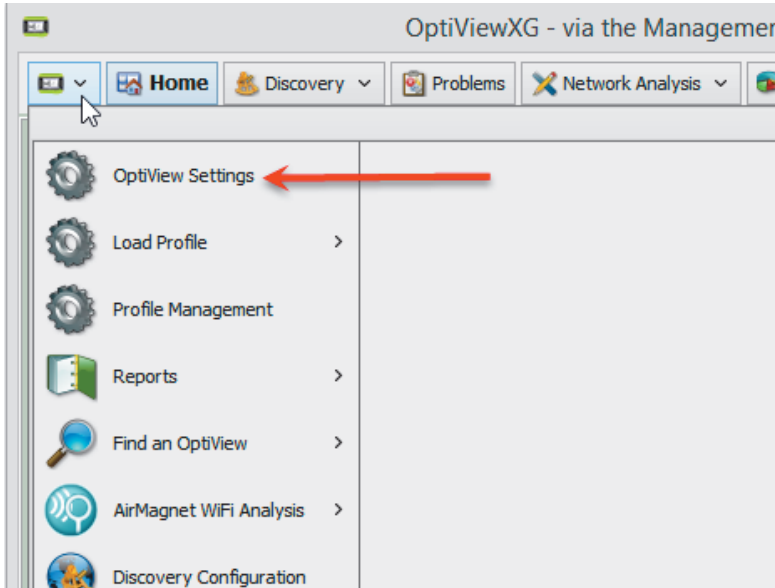

3. Select **OptiView Settings**, and the Options screen is displayed.

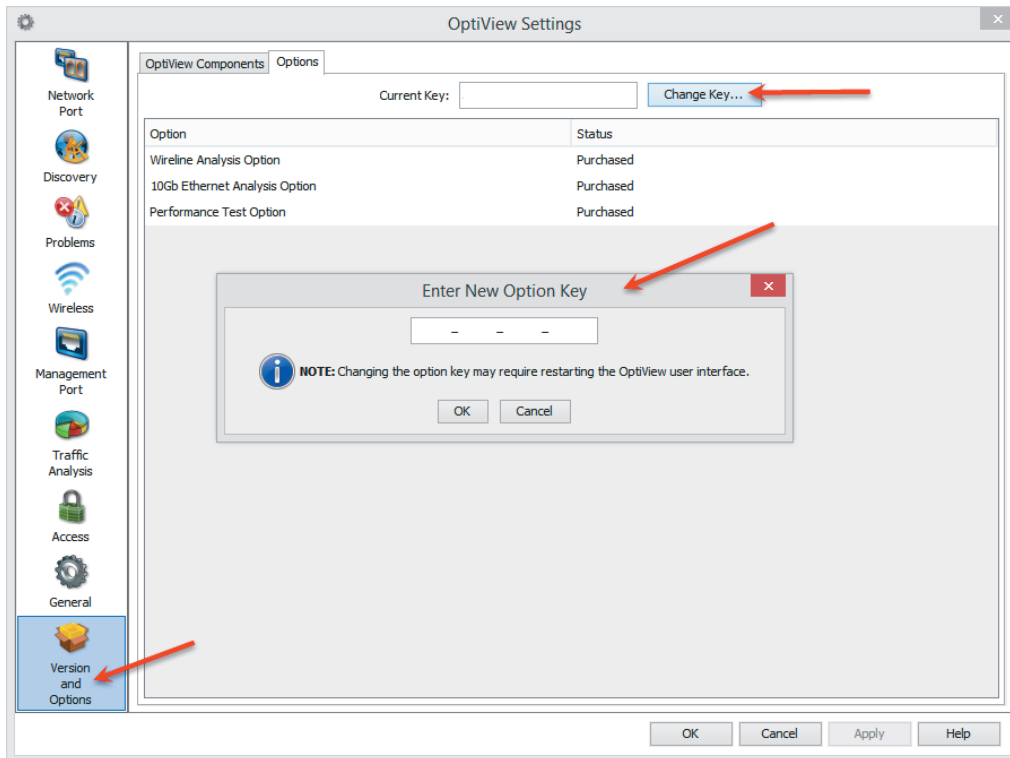

-
4. Select **Change Key** and enter the key code provided.
 5. Select **OK**, then **OK** again. After the OptiView XG reboots, the analyzer user interface is enabled.

